



SWITCH-DISCONNECTOR 80A, FRAME SIZE 1, 3-POLE LATERAL DRIVE  
RIGHT BASIC UNIT WITHOUT HANDLE BOX TERMINAL

Model	
product brand name	SENTRON
product designation	3KD switch disconnecter
design of the product	Switch
display version for switch position indicator door-coupling rotary operating mechanism	ON-OFF
design of the actuating element	Without handle
type of the driving mechanism	Side operating mechanism
type of the driving mechanism motor drive	No
General technical data	
number of poles	3
type of device	fixed mounting
size of switch disconnecter	1
mechanical service life (operating cycles) typical	15 000
electrical endurance (operating cycles)	
• at AC-23 A at 690 V	6 000
• at DC-23 A at 440 V	1 500
I <sup>2</sup> t value	
• with closed switch at 1000 V for combination switch +gG/aM SITOR fuse maximum	2 331 A <sup>2</sup> ·s
• of the fuse at 500 V maximum permissible	34 000 A <sup>2</sup> ·s
• of the gG fuse at 690 V maximum permissible	55 000 A <sup>2</sup> ·s
• of the gG/aM SITOR fuse at 1000 V maximum permissible	6 000 A <sup>2</sup> ·s
• of the molded case circuit breaker at 415 V maximum permissible	480 000 A <sup>2</sup> ·s
position of the switch operating mechanism	at the right end
overvoltage in percent relative to the operating voltage at AC at 400, 500, 690 V at 50/60 Hz	10 %
overvoltage category	III
degree of pollution	3
Voltage	
operating voltage with current paths in series	
• with degree of pollution 2 at DC rated value	440 V / 3
• with degree of pollution 3 at DC rated value	440 V / 3
insulation voltage	
• rated value	1 000 V
surge voltage resistance rated value	8 kV
operational current at AC-22 A at 1000 V maximum	80 A
let-through current of the fuse at 500 V maximum permissible	12 500 A
let-through current of the gG fuse at 690 V maximum	14 700 A

permissible	
<b>Supply voltage</b>	
operating voltage at AC rated value	1 000 V
<b>Protection class</b>	
<b>protection class IP</b>	IP20
<b>protection class IP</b>	
<ul style="list-style-type: none"> <li>with closed switch with cover or cable lug cover</li> </ul>	IP20
<ul style="list-style-type: none"> <li>on the front</li> </ul>	IP20
<b>Dissipation</b>	
<b>power loss [W]</b>	
<ul style="list-style-type: none"> <li>with conventional rated thermal current per pole</li> </ul>	2.1 W
<ul style="list-style-type: none"> <li>with conventional rated thermal current per device</li> </ul>	6.3 W
<ul style="list-style-type: none"> <li>for rated value of the current at AC in hot operating state per pole</li> </ul>	2.1 W
<b>Main circuit</b>	
<b>operating power</b>	
<ul style="list-style-type: none"> <li>at AC-23 A at 500 V rated value</li> </ul>	55 kW
operational current rated value	80 A
<b>Auxiliary circuit</b>	
<b>number of connected NC contacts for auxiliary contacts</b>	0
<b>number of connected NO contacts for auxiliary contacts</b>	0
<b>number of connected CO contacts for auxiliary contacts</b>	0
number of CO contacts for auxiliary contacts	3
<b>number of NC contacts for auxiliary contacts</b>	0
<b>number of NO contacts for auxiliary contacts</b>	0
<b>Suitability</b>	
<b>suitability for use main switch</b>	Yes
<b>suitability for use switch disconnecter</b>	Yes
<b>suitability for use EMERGENCY OFF switch</b>	Yes
<b>suitability for use safety switch</b>	Yes
<b>suitability for use according to IEC 62626-1 safety switch</b>	No
<b>suitability for use maintenance/repair switch</b>	Yes
<b>Product details</b>	
<b>product feature interlock</b>	No
<b>product component</b>	
<ul style="list-style-type: none"> <li>trip indicator</li> </ul>	No
<ul style="list-style-type: none"> <li>voltage trigger</li> </ul>	No
<ul style="list-style-type: none"> <li>undervoltage release</li> </ul>	No
<ul style="list-style-type: none"> <li>undervoltage release with leading contact</li> </ul>	No
<b>product extension auxiliary switch</b>	Yes
<b>product extension optional motor drive</b>	No
<b>product extension optional voltage trigger</b>	No
<b>Short circuit</b>	
<b>short-time withstand current (I<sub>cw</sub>) at 1000 V AC/440 V DC limited to 1 s rated value</b>	3 kA
<b>short-circuit current making capacity (I<sub>cm</sub>) for switch disconnecter</b>	
<ul style="list-style-type: none"> <li>at 1000 V AC without fuse link rated value minimum</li> </ul>	7 kA
<ul style="list-style-type: none"> <li>at DC 440 V without fuse link rated value minimum</li> </ul>	7 kA
<ul style="list-style-type: none"> <li>without fuse link rated value minimum</li> </ul>	7 kA
<b>conditional short-circuit current with line-side fuse protection</b>	
<ul style="list-style-type: none"> <li>at 415 V by molded case circuit breaker rated value</li> </ul>	36 kA
<ul style="list-style-type: none"> <li>at 500 V by gG fuse rated value</li> </ul>	100 kA
<ul style="list-style-type: none"> <li>at 690 V by gG fuse rated value</li> </ul>	100 kA
<b>Connections</b>	
type of connectable conductor cross-sections with flexible busbar	2x (0,8x9 mm <sup>2</sup> )
<b>type of connectable conductor cross-sections</b>	
<ul style="list-style-type: none"> <li>for copper busbar</li> </ul>	'1 x (2 x 9 mm <sup>2</sup> )
<b>type of connectable conductor cross-sections for copper conductor</b>	

<ul style="list-style-type: none"> <li>• solid</li> </ul>	1x (1 ... 16 mm <sup>2</sup> )
<ul style="list-style-type: none"> <li>• finely stranded with core end processing</li> </ul>	1x (1 ... 35 mm <sup>2</sup> )
<ul style="list-style-type: none"> <li>• stranded</li> </ul>	1x (6 ... 35 mm <sup>2</sup> )
type of electrical connection for main current circuit	box terminal

### Mechanical Design

height	119 mm
width	103.3 mm
depth	70 mm
fastening method	Screw fixing and standard rail mounting 35 mm
fastening method	
<ul style="list-style-type: none"> <li>• 4-hole front mounting</li> </ul>	No
<ul style="list-style-type: none"> <li>• front mounting with central attachment</li> </ul>	No
<ul style="list-style-type: none"> <li>• rail mounting</li> </ul>	Yes
mounting position	any
Net Weight	850 g

### Environmental conditions

ambient temperature during operation	
<ul style="list-style-type: none"> <li>• minimum</li> </ul>	-25 °C
<ul style="list-style-type: none"> <li>• maximum</li> </ul>	70 °C
ambient temperature during storage	
<ul style="list-style-type: none"> <li>• minimum</li> </ul>	-50 °C
<ul style="list-style-type: none"> <li>• maximum</li> </ul>	80 °C

### Certificates

reference code according to IEC 81346-2	Q
---	---

### Approvals Certificates

#### General Product Approval



[Miscellaneous](#)



Test Certificates	Maritime application	other	Environment
-------------------	----------------------	-------	-------------

[Type Test Certificates/Test Report](#)



[Confirmation](#)

[Miscellaneous](#)

[Environmental Confirmations](#)

### Environment

[Environmental Confirmations](#)

### Further information

#### Information on the packaging

<https://support.industry.siemens.com/cs/ww/en/view/109813875>

#### Information for data generation and storage

<https://support.industry.siemens.com/cs/ww/en/view/109995012>

#### Information- and Downloadcenter (Catalogs, Brochures,...)

<https://www.siemens.com/lowvoltage/catalogs>

#### Industry Mall (Online ordering system)

<https://mall.industry.siemens.com/mall/en/en/Catalog/product?mlfb=3KD2834-2ME40-0>

#### Service&Support (Manuals, Certificates, Characteristics, FAQs,...)

<https://support.industry.siemens.com/cs/ww/en/ps/3KD2834-2ME40-0>

#### Image database (product images, 2D dimension drawings, 3D models, device circuit diagrams, ...)

[https://www.automation.siemens.com/bilddb/cax\\_en.aspx?mlfb=3KD2834-2ME40-0](https://www.automation.siemens.com/bilddb/cax_en.aspx?mlfb=3KD2834-2ME40-0)

#### CAX-Online-Generator

<https://www.siemens.com/cax>

#### Tender specifications

<https://www.siemens.com/specifications>

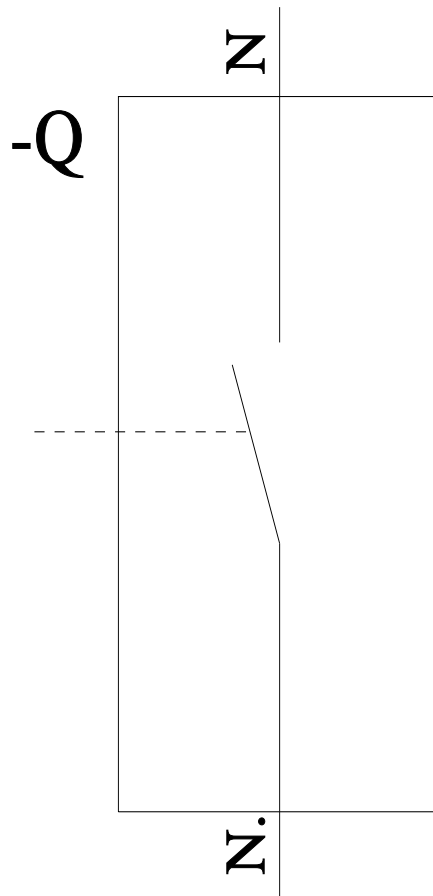
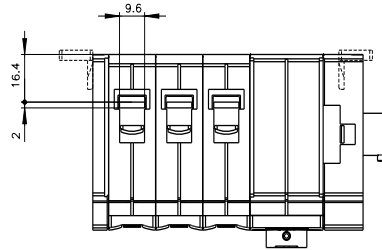
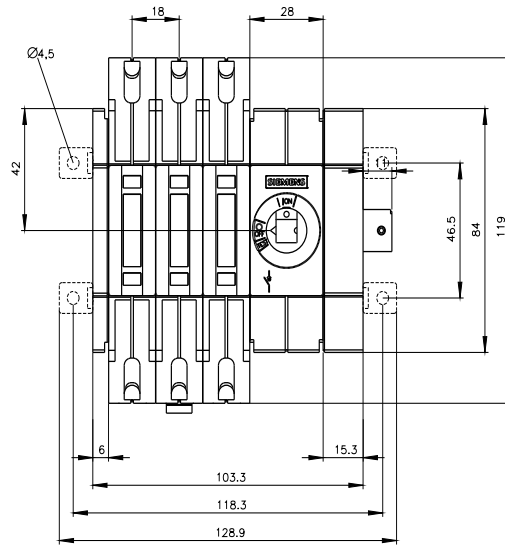
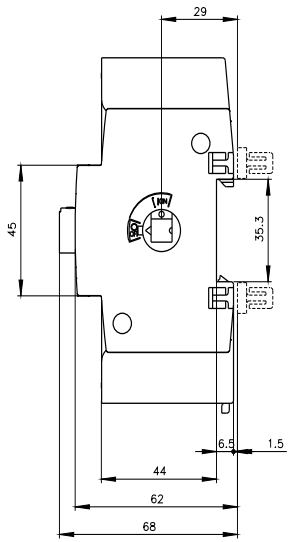

# -CR

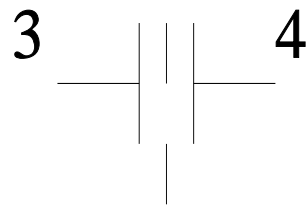

---

last modified:

7/9/2025 

