



switch disconnecter with fuse 250 A, frame size 3, 3-pole for LV HRC fuse size 0 and 1 front operating mechanism left complete unit with direct operating mechanism flat connector without fuses

Model	
product brand name	SENTRON
product designation	3KF switch disconnecter with fuses
design of the product	3KF switch disconnecter with fuses
product version	3KF NH
design of the actuating element	manual operating mechanism
design of handle	Direct operating mechanism, gray
direction of actuation	from the front
type of the driving mechanism motor drive	No
number of poles	3
size of disconnecting link	1 and 0
size of switch disconnecter	3
size of fuse link	NH0, NH1
mechanical service life (operating cycles) typical	10 000
electrical endurance (operating cycles)	
• at AC-23 A at 440 V	5 000
• at AC-23 A at 690 V	4 000
• at DC-23 A at 440 V	1 000
I ² t value	
• with closed switch for combination switch + fuse at 500 V maximum	437 000 A ² ·s
• with closed switch for combination switch + fuse at 400 V maximum	437 000 A ² ·s
• with closed switch at 690 V for combination switch + gG fuse maximum	490 100 A ² ·s
• of the fuse at 500 V maximum permissible	1 500 000 A ² ·s
• of the gG fuse at 690 V maximum permissible	940 000 A ² ·s
• of the aM fuse at 690 V maximum permissible	1 400 000 A ² ·s
position of the switch operating mechanism	left
fuse system	LV HRC fuse
overvoltage category	IV
operating voltage with current paths in series	
• with degree of pollution 2 at DC rated value	440 / 3
• with degree of pollution 3 at DC rated value	440 / 3
surge voltage resistance rated value	12 kV
Supply voltage	
operating voltage at AC rated value maximum	690 V
Protection class	
protection class IP	IP00
protection class IP	
• with closed switch with cover or cable lug cover	IP20

- on the front

IP00

Dissipation

power loss [W]

- | | |
|--|--------|
| • with conventional rated thermal current per pole | 15 W |
| • with conventional rated thermal current per device | 45 W |
| • with conventional rated thermal current without fuse per pole | 15 W |
| • with conventional rated thermal current without fuse per device | 45 W |
| • for rated value of the current at AC in hot operating state per pole | 15 W |
| • of the fuse per fuse maximum | 25.5 W |

Main circuit

- | | |
|---|--------|
| operating power at AC-23 A at 500 V rated value | 160 kW |
| operational current rated value | 250 A |

Auxiliary circuit

- | | |
|---|-----|
| number of connected NC contacts for auxiliary contacts | 0 |
| number of connected NO contacts for auxiliary contacts | 0 |
| number of connected CO contacts for auxiliary contacts | 0 |
| number of CO contacts for auxiliary contacts | 0 |
| number of NC contacts for auxiliary contacts | 8 |
| number of NO contacts for auxiliary contacts | 8 |
| suitability for use main switch | Yes |
| suitability for use switch disconnecter | Yes |
| suitability for use EMERGENCY OFF switch | No |
| suitability for use safety switch | Yes |
| suitability for use maintenance/repair switch | Yes |
| product feature interlock | Yes |
| product function phase failure monitoring | No |
| product component | |
| • voltage trigger | No |
| • undervoltage release | No |
| • undervoltage release with leading contact | No |
| product feature sealable | Yes |
| product extension auxiliary switch | Yes |
| product extension optional locking capability | No |
| product extension optional motor drive | No |
| product extension optional fuse monitoring | Yes |
| product function | |
| • fuse monitoring | No |
| • overvoltage protection monitoring | No |

Short circuit

- | | |
|---|---------|
| short-circuit current making capacity (I _{cm}) for switch disconnecter at 690 V AC/440 V DC without fuse link rated value minimum | 13.6 kA |
| conditional short-circuit current with line-side fuse protection | |
| • at 500 V by gG fuse rated value | 100 kA |
| • at 690 V by gG fuse rated value | 100 kA |

Connections

- | | |
|---|--|
| arrangement of electrical connectors for main current circuit | Top and bottom |
| tightening torque with screw-type terminals | |
| • minimum | 30 N·m |
| • maximum | 44 N·m |
| type of connectable conductor cross-sections for aluminum conductor stranded with lug | 1x (6 ... 240 mm ²), 2x (6 ... 120 mm ²) |
| type of connectable conductor cross-sections | |
| • for copper busbar | 1x (25 x 3 mm ²) |
| type of connectable conductor cross-sections for copper conductor | |
| • stranded with lug according to DIN 46234 | 1x (6 ... 240 mm ²), 2x (6 ... 120 mm ²) |
| • stranded with lug according to DIN 46235 | 1x (6 ... 240 mm ²), 2x (6 ... 120 mm ²) |
| type of electrical connection for main current circuit | flat connector |

Mechanical Design	
height	207 mm
width	249.5 mm
depth	233.3 mm
fastening method	floor mounting
fastening method	
• 4-hole front mounting	No
• front mounting with central attachment	No
• rail mounting	No
mounting position	any
Net Weight	5.636 kg

Environmental conditions	
ambient temperature during operation	
• minimum	-25 °C
• maximum	70 °C
ambient temperature during storage	
• minimum	-50 °C
• maximum	80 °C

Approvals Certificates

General Product Approval



[Miscellaneous](#)



Test Certificates	Maritime application	other	Environment		
Type Test Certificates/Test Report			Miscellaneous	Confirmation	Environmental Confirmations

Environment

[Environmental Confirmations](#)

Further information

- Information on the packaging
<https://support.industry.siemens.com/cs/ww/en/view/109813875>
- Information for data generation and storage
<https://support.industry.siemens.com/cs/ww/en/view/109995012>
- Information- and Downloadcenter (Catalogs, Brochures,...)
<http://www.siemens.com/lowvoltage/catalogs>
- Industry Mall (Online ordering system)
<https://mall.industry.siemens.com/mall/en/en/Catalog/product?mlfb=3KF3325-2LF11>
- Service&Support (Manuals, Certificates, Characteristics, FAQs,...)
<https://support.industry.siemens.com/cs/ww/en/ps/3KF3325-2LF11>
- Image database (product images, 2D dimension drawings, 3D models, device circuit diagrams, ...)
http://www.automation.siemens.com/bilddb/cax_en.aspx?mlfb=3KF3325-2LF11
- CAx-Online-Generator
<http://www.siemens.com/cax>
- Tender specifications
<http://www.siemens.com/specifications>

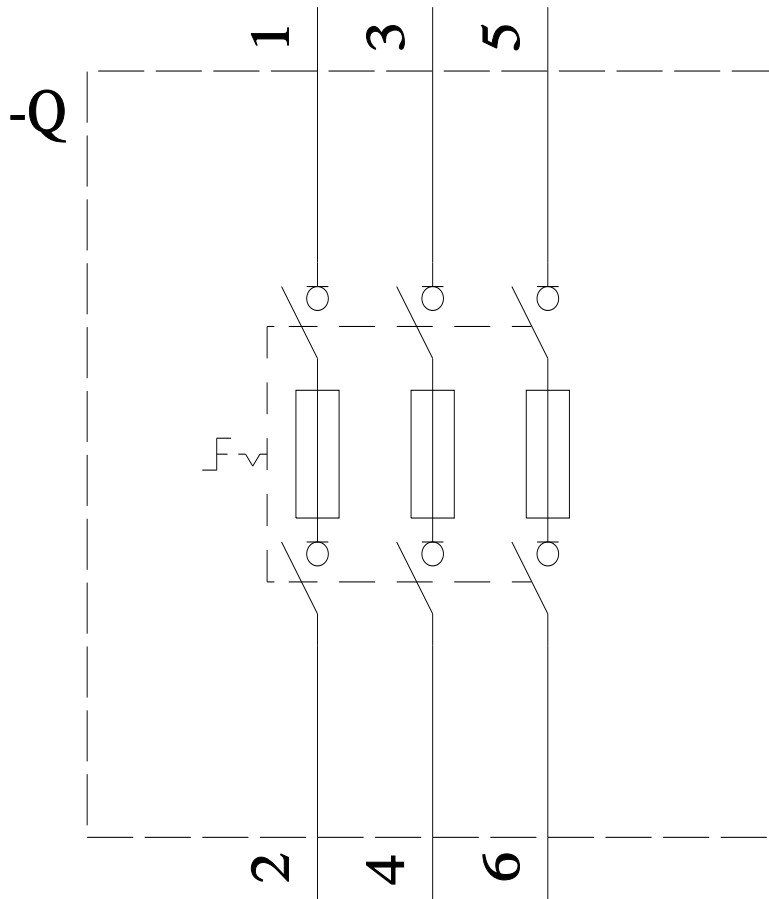
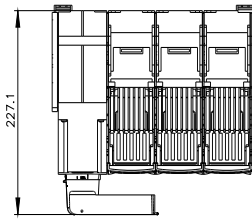
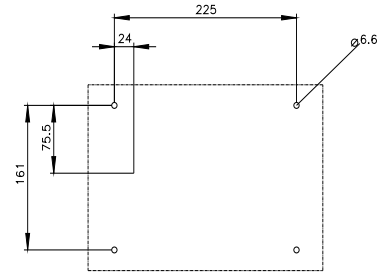
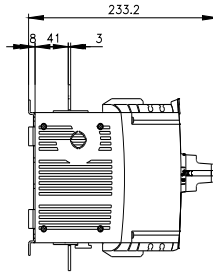
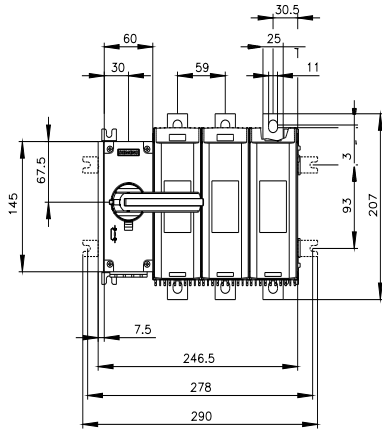



last modified:

4/3/2025 

