



SENTRON switch disconnecter 3LD in the enclosure, maintenance and repair switch with EMC shield plate, 3-pole, I_u: 25 A, AC 23 A, 400 V at 50/60 Hz: 9.5 kW, in frequency converter operation: 20 400 V AC at 0-550 Hz: 5.5 kW, 1 NO + 1 NC 20-150 ms leading, molded-plastic enclosure for metric cable gland, knob-operated mechanism, black, can be locked in 0 and I position, incl. shield terminals

Model	
product brand name	SENTRON
product designation	Switch disconnecter
design of the product	Switch
display version for switch position indicator manual operation	1 ON - 0 OFF
type of switch	Molded-plastic enclosure for metric threaded joint
design of the actuating element	selector switch
color of the actuating element	black
design of handle	knob-operated mechanism, black
type of the driving mechanism motor drive	No
General technical data	
number of poles	3
number of poles note	PE isolated from cable shield
size of switch disconnecter	2
mechanical service life (operating cycles) typical	100 000
electrical endurance (operating cycles)	
• at AC-23 A at 690 V	6 000
• between converter and motor when used as repair switch at AC-20 A at 690 V at 0-550 Hz	100 000
operating frequency maximum	50 1/h
degree of pollution	3
Voltage	
insulation voltage rated value	690 V
surge voltage resistance rated value	6 kV
operating voltage	
• at AC rated value	690 V
• between converter and motor at AC at 0-550 Hz rated value	690 V
operating frequency rated value	
• minimum	50 Hz
• maximum	60 Hz
Protection class	
protection class IP	IP65
degree of protection NEMA rating	1, 3R, 4X
protection class IP on the front	IP65
Dissipation	
power loss [W] for rated value of the current at AC in hot operating state per pole	1.1 W
Main circuit	
operating frequency between converter and motor when	

used as repair switch	
<ul style="list-style-type: none"> initial value full-scale value 	0 Hz 550 Hz
operational current	
<ul style="list-style-type: none"> at AC-21 at 690 V rated value at AC-21 A at 240 V rated value at AC-21 A at 400 V rated value at AC-21 A at 440 V rated value at AC-23 A at 400 V rated value 	25 A 25 A 25 A 25 A 20 A
operating power	
<ul style="list-style-type: none"> at AC-23 A at 240 V rated value at AC-23 A at 440 V rated value at AC-23 A at 690 V rated value at AC-3 at 240 V rated value at AC-3 at 400 V rated value at AC-3 at 690 V rated value 	5 kW 9.5 kW 10 kW 4 kW 8 kW 7.5 kW
operating active power [W] between converter and motor when used as repair switch at AC-20 A	
<ul style="list-style-type: none"> at 400 V at 0-550 Hz rated value at 690 V at 0-550 Hz rated value 	5.5 kW 11 kW
continuous current between converter and motor when used as repair switch at AC-20	
<ul style="list-style-type: none"> at 230 V rated value at 400 V rated value at 690 V rated value 	17.5 A 13.2 A 14 A
Auxiliary circuit	
number of CO contacts for auxiliary contacts	0
number of NC contacts for auxiliary contacts	1
number of NO contacts for auxiliary contacts	1
operating voltage of auxiliary contacts at AC maximum	600 V
continuous current of the auxiliary contact rated value	10 A
insulation voltage of the auxiliary switch rated value	500 V
Suitability	
suitability for use main switch	Yes
suitability for use switch disconnecter	Yes
suitability for use EMERGENCY OFF switch	No
suitability for use safety switch	No
suitability for use maintenance/repair switch	Yes
Product details	
product feature can be locked in ON position	Yes
special product feature	inclusive EMC shield plate
product feature can be locked into OFF position	Yes
Accessories	
product extension optional	
<ul style="list-style-type: none"> motor drive voltage trigger 	No No
number of connectable NC contacts for auxiliary contacts attachable maximum	2
number of connectable NO contacts for auxiliary contacts attachable maximum	4
number of connectable CO contacts for auxiliary contacts attachable maximum	0
number of bracket locks maximum	3
hasp thickness of the bracket locks	4.5 ... 8.5 mm
Short circuit	
conditional short-circuit current with line-side fuse protection	
<ul style="list-style-type: none"> at 690 V by gG fuse rated value 	50 kA
let-through current with closed switch	
<ul style="list-style-type: none"> at 240 V for combination switch + gG fuse maximum at 440 V for combination switch + gG fuse maximum at 690 V for combination switch + gG fuse maximum 	3.5 kA 3.5 kA 4 kA

permissible	
I_{2t} value with closed switch	
<ul style="list-style-type: none"> at 240 V for combination switch + gG fuse maximum at 440 V for combination switch + gG fuse maximum at 690 V for combination switch + gG fuse maximum 	4 kA ₂ .s 4 kA ₂ .s 4 kA ₂ .s
design of the fuse link	
<ul style="list-style-type: none"> for short-circuit protection of the main circuit required for short-circuit protection of the auxiliary switch required 	fuse gL/gG: 25 A fuse gL/gG: 10 A
operational current of upstream fuse rated value	25 A
according UL	
operational current at AC according to UL 508/UL 60947-4-1 rated value	25 A
operating voltage at AC at 50/60 Hz according to UL 508/UL 60947-4-1 rated value	600 V
active power [hp] at AC at 480 V according to UL 508/UL 60947-4-1 rated value	10
active power [hp] at AC at 600 V according to UL 508/UL 60947-4-1 rated value	15
short-time withstand current (SCCR) at 600 V according to UL 508/UL 60947-4-1	5 kA
continuous current of upstream fuse according to UL rated value	50 A
type of fuse according to UL	RK5
Connections	
AWG number as coded connectable conductor cross section solid maximum	
<ul style="list-style-type: none"> 	8 14
type of connectable conductor cross-sections for copper conductor	
<ul style="list-style-type: none"> solid finely stranded with core end processing stranded 	1x (1,5...16mm ²) 1x (1,5...10mm ²) 1x (1,5...16mm ²)
type of connectable conductor cross-sections for auxiliary contacts	
<ul style="list-style-type: none"> solid finely stranded with core end processing stranded 	lateral auxiliary switch 2x (0,75 ... 2,5mm ²), 1x 4mm ² ; front auxiliary switch 1x (0,75 ... 2,5mm ²) lateral auxiliary switch 2x (0,75 ... 1,5mm ²), 1x 2,5mm ² ; front auxiliary switch 1x 2,5mm ² lateral auxiliary switch 2x (0,75 ... 2,5mm ²), 1x 4mm ² ; front auxiliary switch 1x (0,75 ... 2,5mm ²)
type of electrical connection	
<ul style="list-style-type: none"> for main current circuit for auxiliary contacts 	box terminal connection terminals
Mechanical Design	
height	164 mm
width	100 mm
depth	117 mm
type of device	fixed mounting
fastening method	Complete unit in enclosure with EMC shield plate
fastening method	
<ul style="list-style-type: none"> 4-hole front mounting front mounting with central attachment rail mounting 	No Yes No
Net Weight	633 g
Environmental conditions	
ambient temperature during operation	
<ul style="list-style-type: none"> minimum maximum 	-25 °C 55 °C
ambient temperature during storage	
<ul style="list-style-type: none"> minimum maximum 	-25 °C 55 °C
Approvals Certificates	
General Product Approval	Test Certificates



Miscellaneous

Maritime application other Environment



[Confirmation](#)

[Environmental Con-
firmations](#)

[Environmental Con-
firmations](#)

Further information

Information on the packaging

<https://support.industry.siemens.com/cs/ww/en/view/109813875>

Information for data generation and storage

<https://support.industry.siemens.com/cs/ww/en/view/109995012>

Information- and Downloadcenter (Catalogs, Brochures,...)

<https://www.siemens.com/lowvoltage/catalogs>

Industry Mall (Online ordering system)

<https://mall.industry.siemens.com/mall/en/en/Catalog/product?mlfb=3LD2184-2GP21>

Service&Support (Manuals, Certificates, Characteristics, FAQs,...)

<https://support.industry.siemens.com/cs/ww/en/ps/3LD2184-2GP21>

Image database (product images, 2D dimension drawings, 3D models, device circuit diagrams, ...)

https://www.automation.siemens.com/bilddb/cax_en.aspx?mlfb=3LD2184-2GP21

CAX-Online-Generator

<https://www.siemens.com/cax>

Tender specifications

<https://www.siemens.com/specifications>

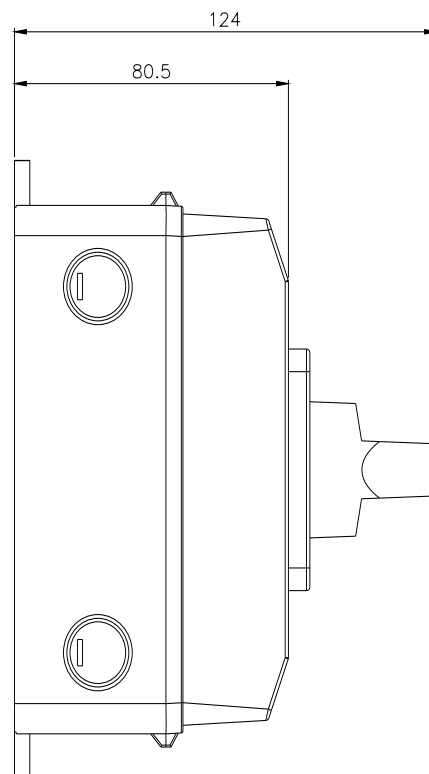
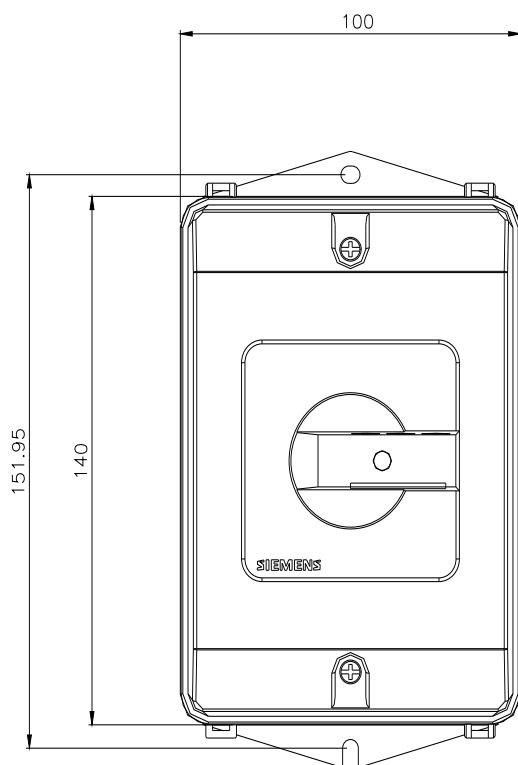



last modified:

10/14/2025

