



SENTRON, Fuse switch disconnecter 3NP1, 3-pole, NH00, 160 A, for Busbar system 8US 60 mm, flat terminal, Fuse monitoring: electromechanical, Cover level 32/70 mm

Model	
product designation	Fuse switch disconnecter
busbar design	busbar thickness 5 or 10 mm
design of the safety monitoring	electro mechanical
design of the load switch strip form	No
type of the driving mechanism motor drive	No
General technical data	
number of poles	3
type of device	For 60 mm 8US busbar system
size of disconnecting link	00 and 000
size of fuse link	NH000, NH00
let-through current with closed switch maximum	23 kA
mechanical service life (operating cycles) typical	2 000
I <sup>2</sup> t value with closed switch maximum	223 kA <sup>2</sup> .s
power factor	
• at AC-22 B	0.65
• at AC-23 B	0.45
• with capacitive load	-0.25
fuse system	LV HRC fuse
degree of pollution	3
Voltage	
insulation voltage	
• rated value	690 V
• with degree of pollution 3 at AC rated value	690 V
• with degree of pollution 2 at AC rated value	1 000 V
power factor at AC-21 B	0.95
surge voltage resistance rated value	8 kV
• operational current	
— at 35 °C rated value	160 A
— at 40 °C rated value	155 A
— at 45 °C rated value	145 A
— at 50 °C rated value	140 A
— at 55 °C rated value	133 A
• operational current	
— at AC-21 B at 240 V rated value	160 A
— at AC-21 B at 400 V rated value	160 A
— at AC-21 B at 500 V rated value	160 A
— at AC-21 B at 690 V rated value	160 A
— at AC-22 B at 240 V rated value	160 A

— at AC-22 B at 400 V rated value	160 A
— at AC-22 B at 500 V rated value	160 A
— at AC-22 B at 690 V rated value	125 A
— at AC-23 B at 690 V rated value	35 A
— at AC-23 B at 500 V rated value	63 A
— at AC-23 B at 400 V rated value	160 A
— at AC-23 B at 240 V rated value	160 A
— at DC-21 B at 120 V rated value	160 A
— at DC-21 B at 240 V rated value	160 A
— at DC-21 B at 440 V rated value	160 A
— at DC-22 B at 120 V rated value	160 A
— at DC-22 B at 240 V rated value	160 A
— at DC-22 B at 440 V rated value	125 A
— at DC-23 B at 120 V rated value	100 A
— at DC-23 B at 240 V rated value	100 A
— at DC-23 B at 440 V rated value	63 A
<b>let-through current with high-speed activation maximum permissible</b>	15 kA
<b>operating voltage</b>	
• at AC rated value minimum	24 V
• at AC rated value maximum	690 V
• at DC rated value	240 V
• at DC rated value minimum	24 V
• at DC rated value maximum	250 V
<b>Protection class</b>	
<b>protection class IP</b>	
• with closed switch with cover or cable lug cover	IP40
• with closed switch without cover or cable lug cover	IP30
• open	IP20
<b>Dissipation</b>	
<b>power loss [W]</b>	
• with conventional rated thermal current without fuse per pole	5 W
• with conventional rated thermal current without fuse per device	15 W
• for rated value of the current at AC in hot operating state per pole	17 W
• of the fuse per fuse maximum	12 W
<b>Main circuit</b>	
<b>operational current</b>	
• rated value	160 A
• with capacitive load at 400 V rated value	72 A
• with capacitive load at 500 V rated value	55 A
<b>Auxiliary circuit</b>	
number of CO contacts for auxiliary contacts	0
<b>number of NC contacts for auxiliary contacts</b>	0
<b>number of NO contacts for auxiliary contacts</b>	0
<b>Suitability</b>	
<b>suitability for use main switch</b>	No
<b>suitability for use switch disconnecter</b>	Yes
<b>suitability for use EMERGENCY OFF switch</b>	No
<b>suitability for use safety switch</b>	Yes
<b>suitability for use maintenance/repair switch</b>	Yes
<b>Product details</b>	
<b>product function phase failure monitoring</b>	No
<b>product component</b>	
• undervoltage release	No
• undervoltage release with leading contact	No
<b>product feature sealable</b>	Yes
<b>product extension auxiliary switch</b>	Yes
<b>product extension optional locking capability</b>	Yes
<b>product extension optional phase failure monitoring</b>	Yes

product extension optional voltage trigger	No
product extension optional overvoltage protection monitoring	Yes
<b>Product function</b>	
product function overvoltage protection monitoring	No
<b>Short circuit</b>	
<b>conditional short-circuit current (I<sub>q</sub>)</b>	
• at AC at 240 V with high-speed activation rated value	80 kA
• at AC at 500 V with high-speed activation rated value	80 kA
• at AC at 690 V with high-speed activation rated value	50 kA
• with closed switch at AC at 240 V rated value	120 kA
• with closed switch at AC at 500 V rated value	120 kA
• with closed switch at AC at 690 V rated value	100 kA
<b>Connections</b>	
arrangement of electrical connectors for main current circuit	other
<b>connectable conductor cross-section for main contacts</b>	
• solid or stranded minimum	2.5 mm <sup>2</sup>
• solid or stranded maximum	95 mm <sup>2</sup>
• stranded minimum	2.5 mm <sup>2</sup>
• stranded maximum	95 mm <sup>2</sup>
<b>tightening torque with screw-type terminals</b>	
• minimum	10 N·m
• maximum	12 N·m
type of connectable conductor cross-sections of the laminated conductors maximum	24 x 12 mm
<b>type of connection technology</b>	Flat terminal
<b>Mechanical Design</b>	
<b>height</b>	206.2 mm
<b>width</b>	105.8 mm
<b>width of the busbar</b>	
• minimum	12 mm
• maximum	30 mm
<b>depth</b>	216.5 mm
<b>fastening method</b>	busbar
<b>fastening method</b>	
• floor mounting	No
• rail mounting	Yes
<b>mounting position</b>	horizontal/vertical
<b>busbar center-to-center spacing</b>	60 mm
<b>Net Weight</b>	1.672 kg
<b>Environmental conditions</b>	
<b>ambient temperature during operation</b>	
• minimum	-25 °C
• maximum	55 °C
<b>ambient temperature during storage</b>	
• minimum	-50 °C
• maximum	80 °C
<b>Certificates</b>	
reference code according to IEC 81346-2	Q
<b>Approvals Certificates</b>	
General Product Approval	



[Miscellaneous](#)

General Product Approval	Test Certificates	Maritime application	other
--------------------------	-------------------	----------------------	-------



Environment

[Environmental Confirmations](#)

[Environmental Confirmations](#)

Further information

Information on the packaging

<https://support.industry.siemens.com/cs/ww/en/view/109813875>

Information for data generation and storage

<https://support.industry.siemens.com/cs/ww/en/view/109995012>

Information- and Downloadcenter (Catalogs, Brochures,...)

<http://www.siemens.com/lowvoltage/catalogs>

Industry Mall (Online ordering system)

<https://mall.industry.siemens.com/mall/en/en/Catalog/product?mlfb=3NP1133-1BC11>

Service&Support (Manuals, Certificates, Characteristics, FAQs,...)

<https://support.industry.siemens.com/cs/ww/en/ps/3NP1133-1BC11>

Image database (product images, 2D dimension drawings, 3D models, device circuit diagrams, ...)

[http://www.automation.siemens.com/bilddb/cax\\_en.aspx?mlfb=3NP1133-1BC11](http://www.automation.siemens.com/bilddb/cax_en.aspx?mlfb=3NP1133-1BC11)

CAX-Online-Generator

<http://www.siemens.com/cax>

Tender specifications

<https://www.siemens.com/specifications>

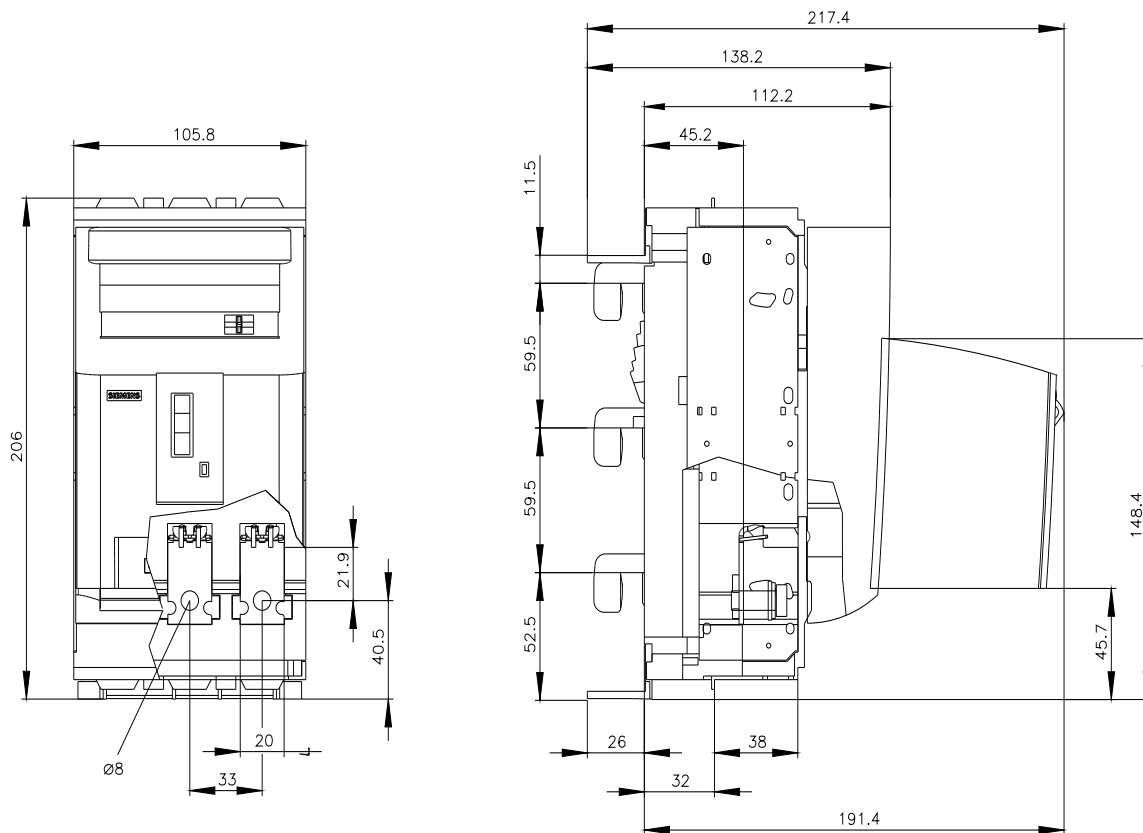

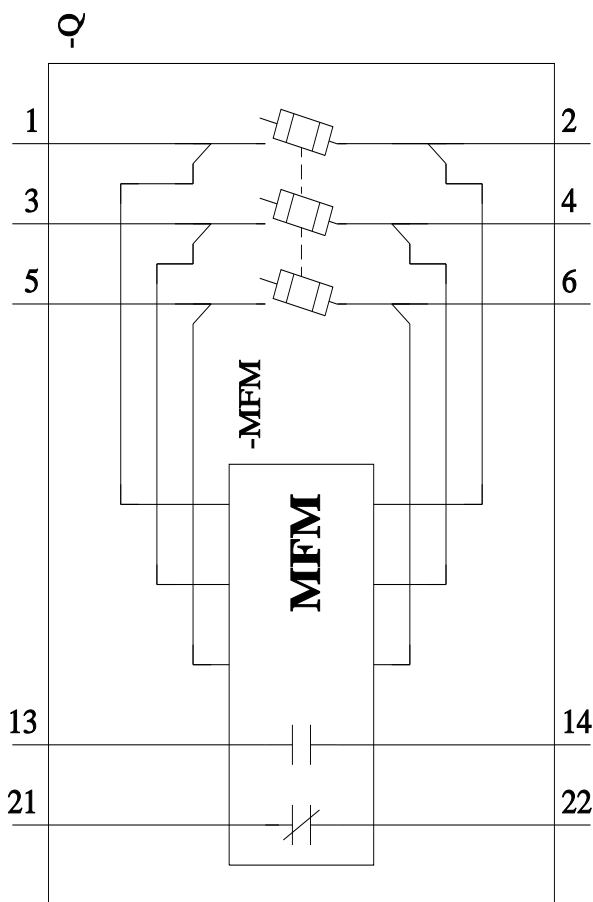
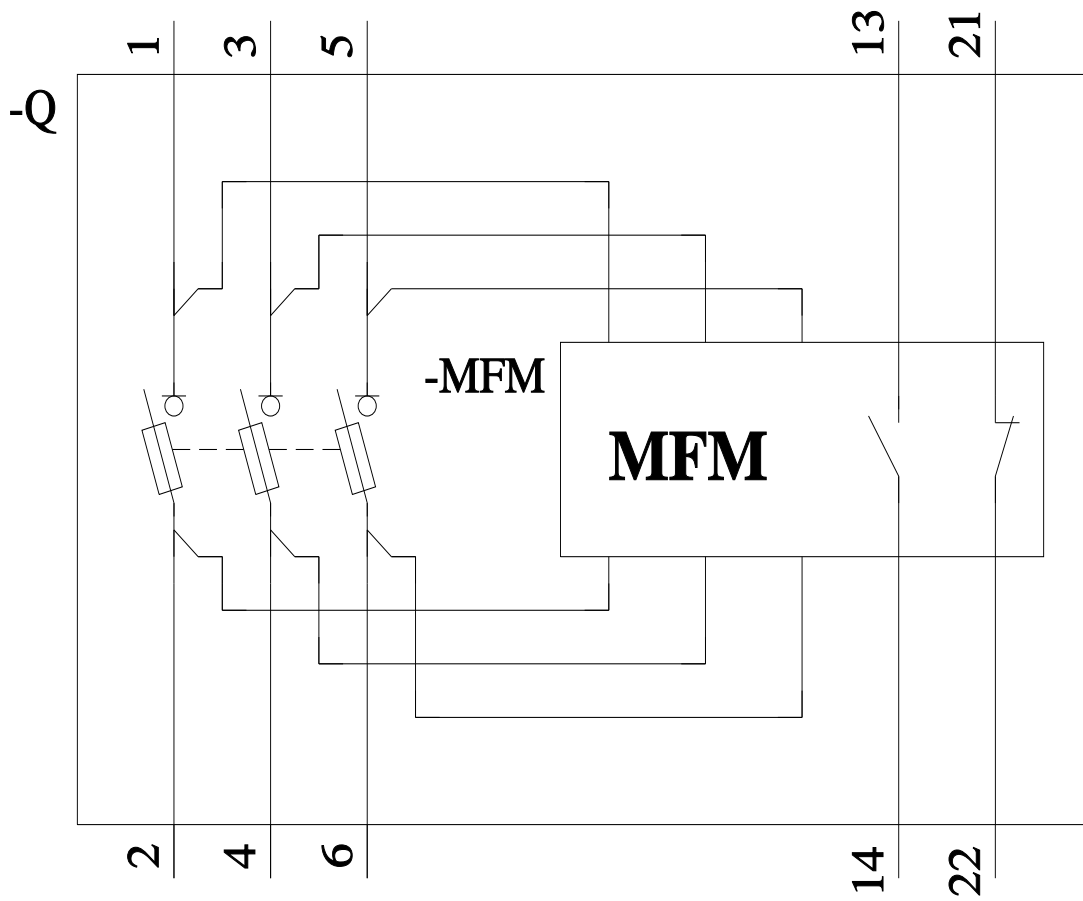

last modified:

4/4/2025 

