



Load feeder fuseless, Reversing duty 400 V AC, Size S00 1.10...1.60 A 24 V DC Spring-type terminal for installation on standard mounting rail (also fulfills type of coordination 1) Type of coordination 2, Iq = 150 kA 1 NC (contactor)

product brand name	SIRIUS
product designation	Reversing starter
design of the product	for DIN-rail or screw mounting
product type designation	3RA22
manufacturer's article number	
<ul style="list-style-type: none"> • of the supplied contactor • of the supplied circuit-breakers • of the supplied link module • of the supplied wiring kit 	3RT2015-2BB42 3RV2011-1AA20 3RA2911-2AA00 3RA2913-2AA2
General technical data	
size of the circuit-breaker	S00
size of load feeder	S00
power loss [W] for rated value of the current	
<ul style="list-style-type: none"> • at AC in hot operating state per pole • without load current share typical 	2.6 W 4 W
insulation voltage with degree of pollution 3 at AC rated value	690 V
surge voltage resistance rated value	6 kV
degree of protection NEMA rating	other
shock resistance according to IEC 60068-2-27	6g / 11 ms
mechanical service life (operating cycles) of contactor typical	30 000 000
type of coordination	2
reference code according to IEC 81346-2:2019	Q
Substance Prohibition (Date)	10/01/2009
SVHC substance name	Lead - 7439-92-1
Weight	1.12 kg
Ambient conditions	
ambient temperature	
<ul style="list-style-type: none"> • during operation • during storage • during transport 	-20 ... +60 °C -50 ... +80 °C -50 ... +80 °C
temperature compensation	-20 ... +60 °C
relative humidity during operation	10 ... 95 %
Main circuit	
number of poles for main current circuit	3
design of the switching contact	electromechanical
adjustable current response value current of the current-dependent overload release	1.1 ... 1.6 A
operating voltage	
<ul style="list-style-type: none"> • rated value • at AC-3 rated value maximum 	690 V 690 V

<ul style="list-style-type: none"> at AC-3e rated value maximum 	690 V
operating frequency rated value	50 ... 60 Hz
operational current	
<ul style="list-style-type: none"> at AC-3 at 400 V rated value 	1.6 A
<ul style="list-style-type: none"> at AC-3e at 400 V rated value 	1.6 A
operating power	
<ul style="list-style-type: none"> at AC-3 <ul style="list-style-type: none"> at 400 V rated value 	550 W
<ul style="list-style-type: none"> at AC-3e <ul style="list-style-type: none"> at 400 V rated value 	550 W
Control circuit/ Control	
type of voltage of the control supply voltage	DC
control supply voltage at DC rated value	24 V
holding power of magnet coil at DC	4 W
Auxiliary circuit	
product extension auxiliary switch	Yes
Protective and monitoring functions	
trip class	CLASS 10
design of the overload release	thermal (bimetallic)
response value current of instantaneous short-circuit trip unit	21 A
UL/CSA ratings	
full-load current (FLA) for 3-phase AC motor	
<ul style="list-style-type: none"> at 480 V rated value 	1.6 A
<ul style="list-style-type: none"> at 600 V rated value 	1.6 A
yielded mechanical performance [hp]	
<ul style="list-style-type: none"> for single-phase AC motor <ul style="list-style-type: none"> at 230 V rated value 	0.1 hp
<ul style="list-style-type: none"> for 3-phase AC motor <ul style="list-style-type: none"> at 220/230 V rated value 	0.5 hp
<ul style="list-style-type: none"> at 460/480 V rated value 	1 hp
<ul style="list-style-type: none"> at 575/600 V rated value 	1 hp
Short-circuit protection	
product function short circuit protection	Yes
design of the short-circuit trip	magnetic
conditional short-circuit current (I_q)	
<ul style="list-style-type: none"> at 400 V according to IEC 60947-4-1 rated value 	150 000 A
Installation/ mounting/ dimensions	
mounting position	vertical
fastening method	screw and snap-on mounting onto 35 mm DIN rail
height	204 mm
width	90 mm
depth	97 mm
required spacing	
<ul style="list-style-type: none"> for grounded parts <ul style="list-style-type: none"> forwards backwards upwards at the side downwards 	32 mm 0 mm 50 mm 10 mm 10 mm
<ul style="list-style-type: none"> for live parts <ul style="list-style-type: none"> forwards backwards upwards downwards at the side 	32 mm 0 mm 50 mm 10 mm 10 mm
Connections/ Terminals	
type of electrical connection	
<ul style="list-style-type: none"> for main current circuit 	spring-loaded terminals
<ul style="list-style-type: none"> for auxiliary and control circuit 	spring-loaded terminals
Safety related data	

product function suitable for safety function	Yes
Electrical Safety	
touch protection on the front according to IEC 60529	finger-safe, for vertical contact from the front
Communication/ Protocol	
protocol is supported	
• PROFINET IO protocol	No
• PROFIsafe protocol	No
protocol is supported AS-Interface protocol	No

Approvals Certificates		
General Product Approval	For use in hazardous locations	Test Certificates



[Type Test Certificates/Test Report](#)

Test Certificates	Maritime application
--------------------------	-----------------------------

[Special Test Certificate](#)



Maritime application	other	Railway	Dangerous goods
-----------------------------	--------------	----------------	------------------------



[Confirmation](#)

[Special Test Certificate](#)

[Transport Information](#)

Environment

[Environmental Conformations](#)

Further information

Information on the packaging

<https://support.industry.siemens.com/cs/ww/en/view/109813875>

Information for data generation and storage

<https://support.industry.siemens.com/cs/ww/en/view/109995012>

Information- and Downloadcenter (Catalogs, Brochures,...)

<https://www.siemens.com/ic10>

Industry Mall (Online ordering system)

<https://mall.industry.siemens.com/mall/en/en/Catalog/product?mlfb=3RA2210-1AE15-2BB4>

Cax online generator

<https://support.automation.siemens.com/WW/CAXorder/default.aspx?lang=en&mlfb=3RA2210-1AE15-2BB4>

Service&Support (Manuals, Certificates, Characteristics, FAQs,...)

<https://support.industry.siemens.com/cs/ww/en/ps/3RA2210-1AE15-2BB4>

Image database (product images, 2D dimension drawings, 3D models, device circuit diagrams, EPLAN macros, ...)

https://www.automation.siemens.com/bilddb/cax_de.aspx?mlfb=3RA2210-1AE15-2BB4&lang=en

Characteristic: Tripping characteristics, I²t, Let-through current

<https://support.industry.siemens.com/cs/ww/en/ps/3RA2210-1AE15-2BB4/char>

Further characteristics (e.g. electrical endurance, switching frequency)

<https://www.automation.siemens.com/bilddb/index.aspx?view=Search&mlfb=3RA2210-1AE15-2BB4&objecttype=14&gridview=view1>

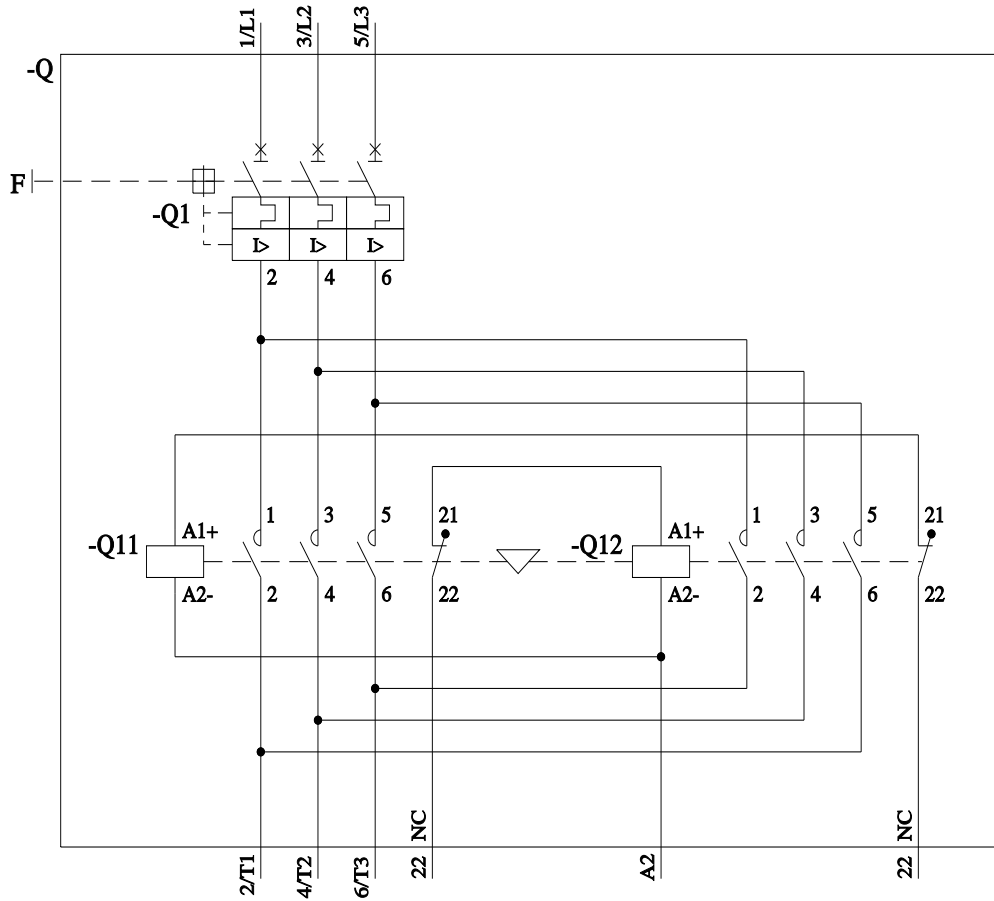

last modified:

4/1/2025