



semiconductor relay, 1-phase 3RF2 width 45 mm, 90 A 48-460 V / 24 V DC screw terminal for mounting on available cooling surfaces

| | |
|---|--|
| product brand name | SIRIUS |
| product designation | solid-state relay |
| design of the product | 1-pole |
| product type designation | 3RF20 |
| General technical data | |
| product function | zero-point switching |
| power loss [W] for rated value of the current | |
| • at AC in hot operating state | 118 W |
| • at AC in hot operating state per pole | 118 W |
| • without load current share typical | 0.4 W |
| insulation voltage rated value | 600 V |
| protection class IP | IP20 |
| protection class IP on the front according to IEC 60529 | IP20 |
| shock resistance according to IEC 60068-2-27 | 15g / 11 ms |
| vibration resistance according to IEC 60068-2-6 | 2g |
| reference code according to IEC 81346-2 | Q |
| Substance Prohibitance (Date) | 05/28/2009 |
| SVHC substance name | Lead - 7439-92-1 Lead monoxide (lead oxide) - 1317-36-8 |
| Weight | 0.084 kg |
| Main circuit | |
| number of poles for main current circuit | 1 |
| number of NO contacts for main contacts | 1 |
| number of NC contacts for main contacts | 0 |
| type of voltage of the operating voltage | AC |
| operating voltage | |
| • at AC | |
| — at 50 Hz rated value | 48 ... 460 V |
| — at 60 Hz rated value | 48 ... 460 V |
| operating frequency rated value | 50 ... 60 Hz |
| relative symmetrical tolerance of the operating frequency | 10 % |
| operating range relative to the operating voltage at AC | |
| • at 50 Hz | 40 ... 506 V |
| • at 60 Hz | 40 ... 506 V |
| operational current rated value maximum | 88 A |
| operational current | |
| • at AC-51 rated value | 50 A |
| • according to UL 508 rated value | 50 A |
| operational current minimum | 500 mA |
| rate of voltage rise at the thyristor for main contacts maximum permissible | 1 000 V/ μ s |

| | |
|--|---|
| blocking voltage at the thyristor for main contacts maximum permissible | 1 200 V |
| reverse current of the thyristor | 10 mA |
| derating temperature | 40 °C |
| surge current resistance rated value | 1 150 A |
| I²t value maximum | 6 600 A ² ·s |
| Control circuit/ Control | |
| type of voltage of the control supply voltage | DC |
| control supply voltage 1 at DC rated value maximum permissible | 30 V |
| control supply voltage 1 at DC | 15 ... 24 V |
| control supply voltage | |
| • at DC initial value for signal <1> detection | 15 V |
| • at DC full-scale value for signal<0> recognition | 5 V |
| control current at minimum control supply voltage | |
| • at DC | 13 mA |
| control current at DC rated value | 15 mA |
| ON-delay time | 1 ms; additionally max. one half-wave |
| OFF-delay time | 1 ms; additionally max. one half-wave |
| Auxiliary circuit | |
| type of switching contact | normally open contact (NO) |
| number of NC contacts for auxiliary contacts | 0 |
| number of NO contacts for auxiliary contacts | 0 |
| number of CO contacts for auxiliary contacts | 0 |
| Installation/ mounting/ dimensions | |
| fastening method side-by-side mounting | Yes |
| fastening method | screw fixing |
| design of the thread of the screw for securing the equipment | M4 |
| tightening torque of fixing screw maximum | 1.5 N·m |
| tightening torque [lbf·in] of fixing screw maximum | 13 lbf·in |
| height | 58 mm |
| width | 45 mm |
| depth | 48 mm |
| Connections/ Terminals | |
| product component removable terminal for auxiliary and control circuit | Yes |
| type of electrical connection | |
| • for main current circuit | screw-type terminals |
| • for auxiliary and control circuit | screw-type terminals |
| type of connectable conductor cross-sections | |
| • for main contacts | |
| — solid | 2x (1.5 ... 2.5 mm ²), 2x (2.5 ... 6 mm ²) |
| — finely stranded with core end processing | 2x (1 ... 2.5 mm ²), 2x (2.5 ... 6 mm ²), 1x 10 mm ² |
| • for AWG cables for main contacts | 2x (14 ... 10) |
| connectable conductor cross-section for main contacts | |
| • solid or stranded | 1.5 ... 6 mm ² |
| • finely stranded with core end processing | 1 ... 10 mm ² |
| type of connectable conductor cross-sections | |
| • for auxiliary and control contacts | |
| — solid | 1x (0.5 ... 2.5 mm ²), 2x (0.5 ... 1 mm ²) |
| — finely stranded with core end processing | 1x (0.5 ... 2.5 mm ²), 2x (0.5 ... 1 mm ²) |
| — finely stranded without core end processing | 1x (0.5 ... 2.5 mm ²), 2x (0.5 ... 1 mm ²) |
| • for AWG cables for auxiliary and control contacts | 1x (20 ... 12) |
| AWG number as coded connectable conductor cross section for main contacts | 14 ... 10 |
| tightening torque | |
| • for main contacts with screw-type terminals | 2 ... 2.5 N·m |
| • for auxiliary and control contacts with screw-type terminals | 0.5 ... 0.6 N·m |
| tightening torque [lbf·in] | |
| • for main contacts with screw-type terminals | 7 ... 10.3 lbf·in |

| | |
|---|--|
| <ul style="list-style-type: none"> for auxiliary and control contacts with screw-type terminals | 4.5 ... 5.3 lbf-in |
| design of the thread of the connection screw | |
| <ul style="list-style-type: none"> for main contacts of the auxiliary and control contacts | M4 M3 |
| stripped length of the cable | |
| <ul style="list-style-type: none"> for main contacts for auxiliary and control contacts | 10 mm 7 mm |
| Electrical Safety | |
| protection class IP on the front according to IEC 60529 | IP20 |
| touch protection on the front according to IEC 60529 | finger-safe, for vertical contact from the front |
| Ambient conditions | |
| installation altitude at height above sea level maximum | 1 000 m |
| ambient temperature | |
| <ul style="list-style-type: none"> during operation during storage | -25 ... +60 °C -55 ... +80 °C |
| Electromagnetic compatibility | |
| conducted interference | |
| <ul style="list-style-type: none"> due to burst according to IEC 61000-4-4 due to conductor-earth surge according to IEC 61000-4-5 due to conductor-conductor surge according to IEC 61000-4-5 due to high-frequency radiation according to IEC 61000-4-6 | 2 kV / 5 kHz behavior criterion 2 2 kV behavior criterion 2 1 kV behavior criterion 2 140 dBuV in the frequency range 0.15 ... 80 MHz, behavior criterion 1 |
| field-based interference according to IEC 61000-4-3 | 80 MHz ... 1 GHz 10 V/m, behavior criterion 1 |
| electrostatic discharge according to IEC 61000-4-2 | 4 kV contact discharging / 8 kV air discharging, behavior criterion 2 |
| conducted HF interference emissions according to CISPR11 | Class A for industrial environment |
| field-bound HF interference emission according to CISPR11 | Class B for the domestic, business and commercial environments |
| Short-circuit protection, design of the fuse link | |
| <p>manufacturer's article number</p> <ul style="list-style-type: none"> of full range R fuse link for semiconductor protection at NH design usable of back-up R fuse link for semiconductor protection at NH design usable of back-up R fuse link for semiconductor protection at cylindrical design 22 x 58 mm usable | 3NE1021-2 3NE8021-1 3NC2280 |
| <p>manufacturer's article number of the gG fuse</p> <ul style="list-style-type: none"> at NH design usable at cylindrical design 22 x 58 mm usable | 3NA6812: These fuses have a smaller rated current than the semiconductor relays 3NW6212-1: These fuses have a smaller rated current than the semiconductor relays |
| <p>manufacturer's article number</p> <ul style="list-style-type: none"> of DIAZED fuse usable of NEOZED fuse usable | 5SB4111: These fuses have a smaller rated current than the semiconductor relays 5SE2335: These fuses have a smaller rated current than the semiconductor relays |
| Approvals Certificates | |
| General Product Approval | EMV |



Test Certificates

other

Environment

[Type Test Certificates/Test Report](#)



[Confirmation](#)

[Environmental Confirmations](#)

Further information

Information on the packaging

<https://support.industry.siemens.com/cs/ww/en/view/109813875>

Information for data generation and storage

<https://support.industry.siemens.com/cs/ww/en/view/109995012>

Information- and Downloadcenter (Catalogs, Brochures,...)

<https://www.siemens.com/ic10>

Industry Mall (Online ordering system)

<https://mall.industry.siemens.com/mall/en/en/Catalog/product?mlfb=3RF2090-1AA04>

Cax online generator

<https://support.automation.siemens.com/WW/CAXorder/default.aspx?lang=en&mlfb=3RF2090-1AA04>

Service&Support (Manuals, Certificates, Characteristics, FAQs,...)

<https://support.industry.siemens.com/cs/ww/en/ps/3RF2090-1AA04>

Image database (product images, 2D dimension drawings, 3D models, device circuit diagrams, EPLAN macros, ...)

https://www.automation.siemens.com/bilddb/cax_de.aspx?mlfb=3RF2090-1AA04&lang=en

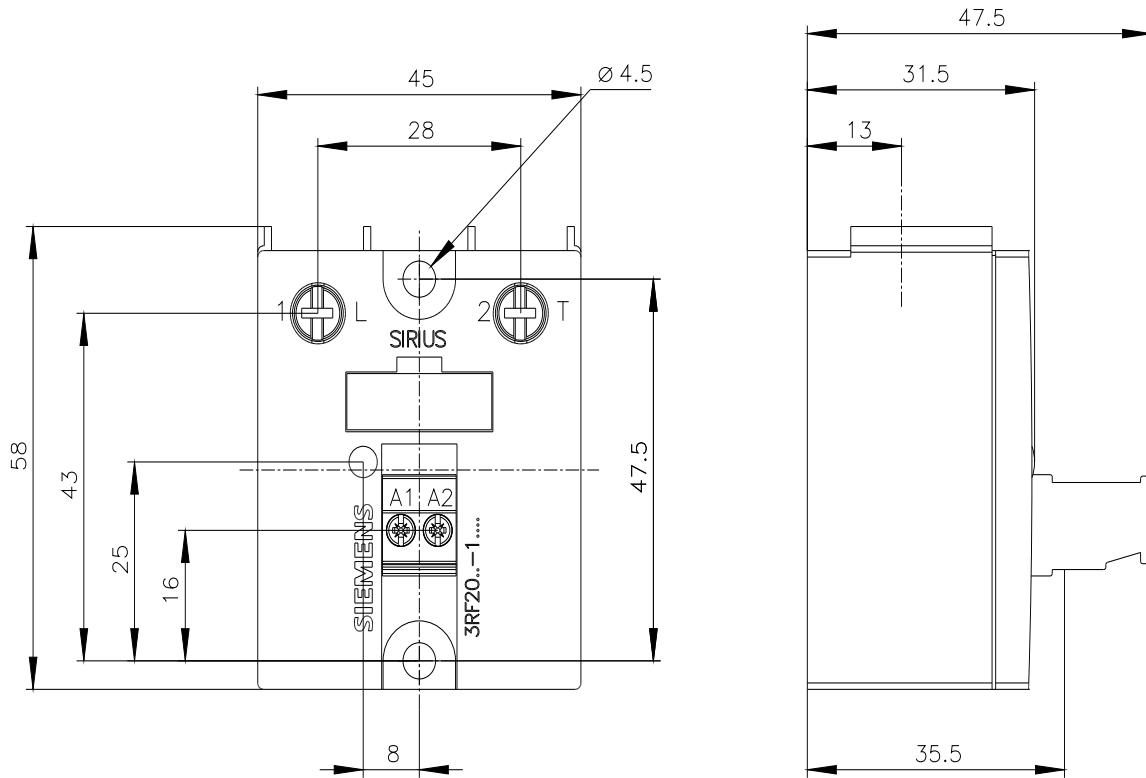

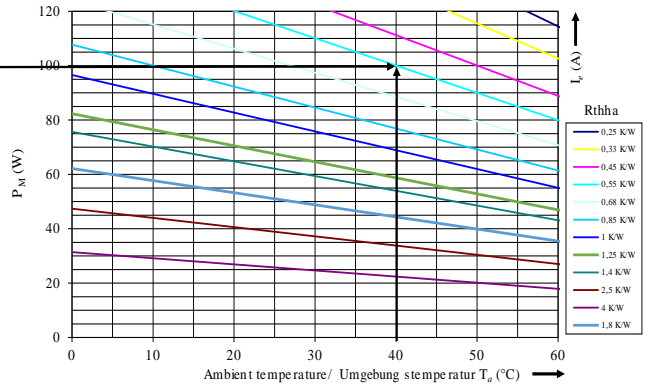
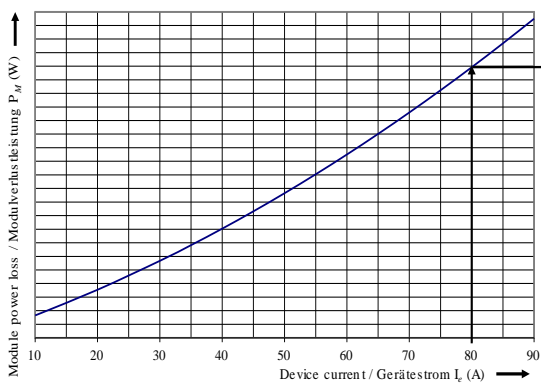

last modified:

8/4/2025