







Solid-state contactor 3-phase 3RF2 AC 51 / 30 A / 40 °C 48-600 V / 110 V AC 3-phase controlled screw terminal Blocking voltage 1200 V

product brand name	SIRIUS
product designation	solid-state contactor
design of the product	3-pole controlled
product type designation	3RF24
<b>General technical data</b>	
product function	zero-point switching
power loss [W] for rated value of the current	
• at AC in hot operating state	91 W
• at AC in hot operating state per pole	30.33 W
• without load current share typical	1.9 W
insulation voltage rated value	600 V
degree of pollution	3
surge voltage resistance of main circuit rated value	6 kV
protection class IP	IP20
protection class IP on the front according to IEC 60529	IP20
shock resistance according to IEC 60068-2-27	15g / 11 ms
vibration resistance according to IEC 60068-2-6	2g
reference code according to IEC 81346-2	Q
Substance Prohibitance (Date)	07/01/2006
SVHC substance name	Lead - 7439-92-1 Lead monoxide (lead oxide) - 1317-36-8 Dibutylbis(pentane-2,4-dionato-O,O')tin - 22673-19-4
Weight	0.56 kg
<b>Main circuit</b>	
number of poles for main current circuit	3
number of NO contacts for main contacts	3
number of NC contacts for main contacts	0
type of voltage of the operating voltage	AC
operating voltage	
• at AC	
— at 50 Hz rated value	48 ... 600 V
— at 60 Hz rated value	48 ... 600 V
operating frequency rated value	50 ... 60 Hz
relative symmetrical tolerance of the operating frequency	10 %
operating range relative to the operating voltage at AC	
• at 50 Hz	40 ... 660 V
• at 60 Hz	40 ... 660 V
operational current	
• at AC-51 rated value	30 A
• at AC-51 according to IEC 60947-4-3	22 A
• according to UL 508 rated value	22 A

<b>operational current minimum</b>	500 mA
<b>rate of voltage rise at the thyristor for main contacts maximum permissible</b>	1 000 V/ $\mu$ s
<b>blocking voltage at the thyristor for main contacts maximum permissible</b>	1 200 V
<b>reverse current of the thyristor</b>	10 mA
<b>derating temperature</b>	40 °C
<b>surge current resistance rated value</b>	1 200 A
<b>I<sup>2</sup>t value maximum</b>	7 200 A <sup>2</sup> ·s
<b>Control circuit/ Control</b>	
<b>type of voltage of the control supply voltage</b>	AC
<b>control supply voltage 1 at AC</b>	
• at 50 Hz	90 ... 125 V
• at 60 Hz	90 ... 125 V
<b>control supply voltage frequency</b>	
• 1 rated value	45 Hz
• 2 rated value	66 Hz
<b>control supply voltage at AC</b>	
• at 50 Hz full-scale value for signal<0> recognition	40 V
• at 60 Hz full-scale value for signal<0> recognition	90 V
<b>control supply voltage</b>	
• at AC initial value for signal <1> detection	90 V
<b>symmetrical line frequency tolerance</b>	5 Hz
<b>control current at minimum control supply voltage</b>	
• at AC	2 mA
control current at AC rated value	15 mA
<b>ON-delay time</b>	40 ms; additionally max. one half-wave
<b>Auxiliary circuit</b>	
<b>type of switching contact</b>	normally open contact (NO)
<b>number of NC contacts for auxiliary contacts</b>	0
<b>number of NO contacts for auxiliary contacts</b>	0
number of CO contacts for auxiliary contacts	0
<b>Installation/ mounting/ dimensions</b>	
fastening method side-by-side mounting	Yes
<b>fastening method</b>	screw fixing and snap-on mounting on standard mounting rail 35 mm according to IEC 60715
<b>design of the thread of the screw for securing the equipment</b>	M4
<b>height</b>	100 mm
<b>width</b>	89.5 mm
<b>depth</b>	128 mm
<b>Connections/ Terminals</b>	
<b>product component removable terminal for auxiliary and control circuit</b>	Yes
<b>type of electrical connection</b>	
• for main current circuit	screw-type terminals
• for auxiliary and control circuit	screw-type terminals
<b>type of connectable conductor cross-sections</b>	
• for main contacts	
— solid	2x (1.5 ... 2.5 mm <sup>2</sup> ), 2x (2.5 ... 6 mm <sup>2</sup> )
— finely stranded with core end processing	2x (1 ... 2.5 mm <sup>2</sup> ), 2x (2.5 ... 6 mm <sup>2</sup> ), 1x 10 mm <sup>2</sup>
• for AWG cables for main contacts	2x (14 ... 10)
<b>connectable conductor cross-section for main contacts</b>	
• solid or stranded	1.5 ... 6 mm <sup>2</sup>
• finely stranded with core end processing	1 ... 10 mm <sup>2</sup>
<b>type of connectable conductor cross-sections</b>	
• for auxiliary and control contacts	
— solid	1x (0.5 ... 2.5 mm <sup>2</sup> ), 2x (0.5 ... 1 mm <sup>2</sup> )
— finely stranded with core end processing	1x (0.5 ... 2.5 mm <sup>2</sup> ), 2x (0.5 ... 1 mm <sup>2</sup> )
— finely stranded without core end processing	1x (0.5 ... 2.5 mm <sup>2</sup> ), 2x (0.5 ... 1 mm <sup>2</sup> )
• for AWG cables for auxiliary and control contacts	1x (20 ... 12)
<b>AWG number as coded connectable conductor cross</b>	14 ... 10

<b>section for main contacts</b>		
<b>tightening torque</b>		
<ul style="list-style-type: none"> <li>• for main contacts with screw-type terminals</li> <li>• for auxiliary and control contacts with screw-type terminals</li> </ul>	2 ... 2.5 N·m 0.5 ... 0.6 N·m	
<b>tightening torque [lbf·in]</b>		
<ul style="list-style-type: none"> <li>• for main contacts with screw-type terminals</li> <li>• for auxiliary and control contacts with screw-type terminals</li> </ul>	18 ... 22 lbf·in 7.5 ... 5.3 lbf·in	
<b>design of the thread of the connection screw</b>		
<ul style="list-style-type: none"> <li>• for main contacts</li> <li>• of the auxiliary and control contacts</li> </ul>	M4 M3	
<b>stripped length of the cable</b>		
<ul style="list-style-type: none"> <li>• for main contacts</li> <li>• for auxiliary and control contacts</li> </ul>	10 mm 7 mm	
<b>Electrical Safety</b>		
<b>protection class IP on the front according to IEC 60529</b>	IP20	
<b>touch protection on the front according to IEC 60529</b>	finger-safe, for vertical contact from the front	
<b>Ambient conditions</b>		
installation altitude at height above sea level maximum	1 000 m	
<b>ambient temperature</b>		
<ul style="list-style-type: none"> <li>• during operation</li> <li>• during storage</li> </ul>	-25 ... +60 °C -55 ... +80 °C	
<b>Electromagnetic compatibility</b>		
<b>conducted interference</b>		
<ul style="list-style-type: none"> <li>• due to burst according to IEC 61000-4-4</li> <li>• due to conductor-earth surge according to IEC 61000-4-5</li> <li>• due to conductor-conductor surge according to IEC 61000-4-5</li> <li>• due to high-frequency radiation according to IEC 61000-4-6</li> </ul>	2 kV / 5 kHz behavior criterion 2 2 kV behavior criterion 2 1 kV behavior criterion 2 140 dBuV in the frequency range 0.15 ... 80 MHz, behavior criterion 1	
<b>electrostatic discharge according to IEC 61000-4-2</b>	4 kV contact discharging / 8 kV air discharging, behavior criterion 2	
<b>conducted HF interference emissions according to CISPR11</b>	Class A for industrial environment	
<b>field-bound HF interference emission according to CISPR11</b>	Class A for industrial environment	
<b>Short-circuit protection, design of the fuse link</b>		
manufacturer's article number <ul style="list-style-type: none"> <li>• of full range R fuse link for semiconductor protection at NH design usable</li> <li>• of full range R fuse link for semiconductor protection at cylindrical design usable</li> <li>• of back-up R fuse link for semiconductor protection at NH design usable</li> <li>• of back-up R fuse link for semiconductor protection at cylindrical design 10 x 38 mm usable</li> <li>• of back-up R fuse link for semiconductor protection at cylindrical design 14 x 51 mm usable</li> <li>• of back-up R fuse link for semiconductor protection at cylindrical design 22 x 58 mm usable</li> </ul>	<a href="#">3NE1803-0</a> <a href="#">5SE1335: Maximum operating voltage 400 V!</a> <a href="#">3NE8003-1</a> <a href="#">3NC1032</a> <a href="#">3NC1450</a> <a href="#">3NC2280</a>	
manufacturer's article number of the gG fuse at NH design usable <ul style="list-style-type: none"> <li>• up to 460 V</li> </ul>	<a href="#">3NA3812</a>	
<b>Approvals Certificates</b>		
<b>General Product Approval</b>	<b>EMV</b>	<b>Test Certificates</b>
    		<a href="#">Type Test Certificates/Test Report</a>
<b>other</b>	<b>Environment</b>	



[Confirmation](#)



[Environmental Confirmations](#)

#### Further information

##### Information on the packaging

<https://support.industry.siemens.com/cs/ww/en/view/109813875>

##### Information for data generation and storage

<https://support.industry.siemens.com/cs/ww/en/view/109995012>

##### Information- and Downloadcenter (Catalogs, Brochures,...)

<https://www.siemens.com/ic10>

##### Industry Mall (Online ordering system)

<https://mall.industry.siemens.com/mall/en/en/Catalog/product?mlfb=3RF2430-1AC35>

##### Cax online generator

<https://support.automation.siemens.com/WW/CAXorder/default.aspx?lang=en&mlfb=3RF2430-1AC35>

##### Service&Support (Manuals, Certificates, Characteristics, FAQs,...)

<https://support.industry.siemens.com/cs/ww/en/ps/3RF2430-1AC35>

##### Image database (product images, 2D dimension drawings, 3D models, device circuit diagrams, EPLAN macros, ...)

[https://www.automation.siemens.com/bilddb/cax\\_de.aspx?mlfb=3RF2430-1AC35&lang=en](https://www.automation.siemens.com/bilddb/cax_de.aspx?mlfb=3RF2430-1AC35&lang=en)

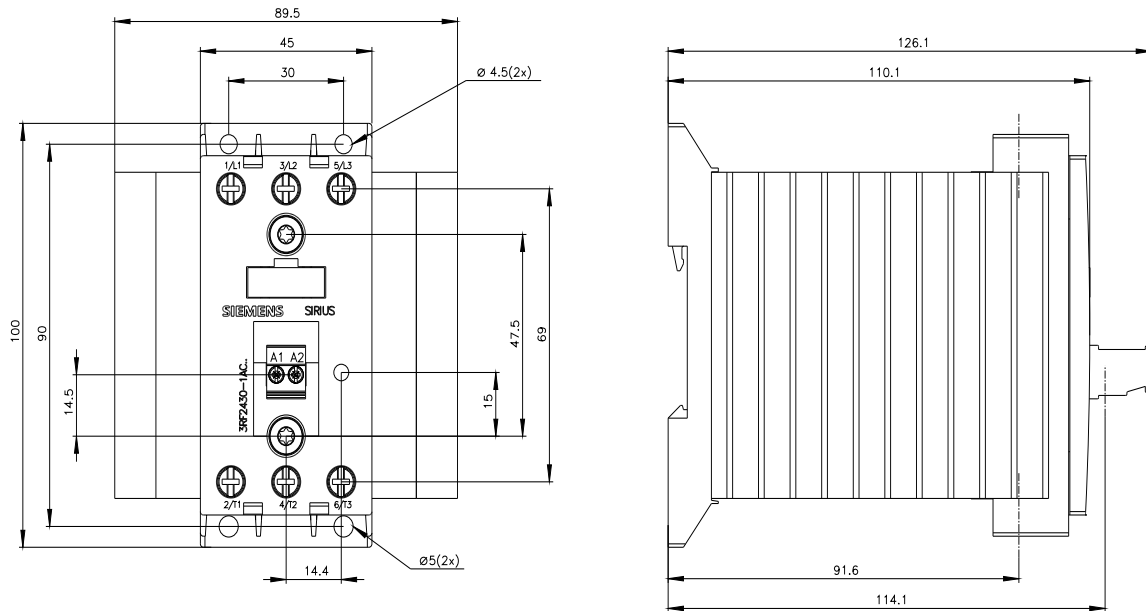

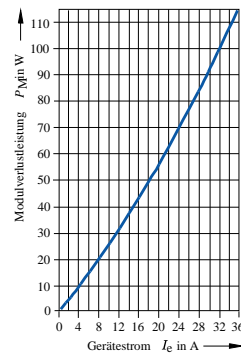
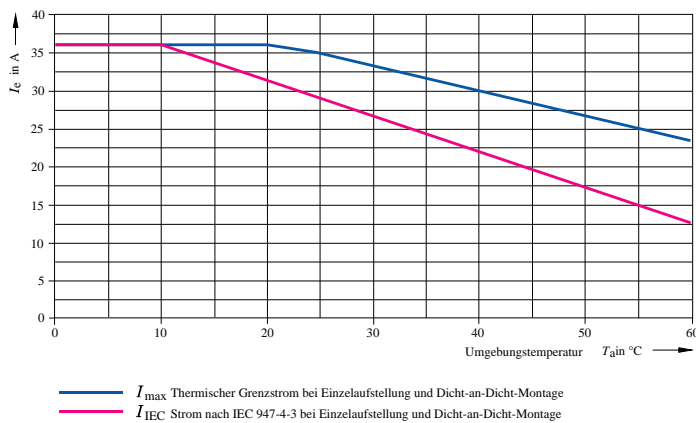

last modified:

8/4/2025