



Solid-state contactor 3-phase 3RF2 AC 51 / 50 A / 40 °C 48-600 V / 230 V AC 2-phase controlled Ring cable connection Blocking voltage 1200 V

product brand name	SIRIUS
product designation	solid-state contactor
design of the product	2-pole controlled
product type designation	3RF24
General technical data	
product function	zero-point switching
power loss [W] for rated value of the current	
• at AC in hot operating state	107 W
• at AC in hot operating state per pole	35.67 W
• without load current share typical	3.5 W
insulation voltage rated value	600 V
degree of pollution	3
surge voltage resistance of main circuit rated value	6 kV
protection class IP	IP00
protection class IP on the front according to IEC 60529	IP00
shock resistance according to IEC 60068-2-27	15g / 11 ms
vibration resistance according to IEC 60068-2-6	2g
reference code according to IEC 81346-2	Q
Substance Prohibitance (Date)	07/01/2006
SVHC substance name	Lead - 7439-92-1 Lead monoxide (lead oxide) - 1317-36-8 Dibutylbis(pentane-2,4-dionato-O,O')tin - 22673-19-4
Weight	0.721 kg
Main circuit	
number of poles for main current circuit	3
number of NO contacts for main contacts	2
number of NC contacts for main contacts	0
type of voltage of the operating voltage	AC
operating voltage	
• at AC	
— at 50 Hz rated value	48 ... 600 V
— at 60 Hz rated value	48 ... 600 V
operating frequency rated value	50 ... 60 Hz
relative symmetrical tolerance of the operating frequency	10 %
operating range relative to the operating voltage at AC	
• at 50 Hz	40 ... 660 V
• at 60 Hz	40 ... 660 V
operational current	
• at AC-51 rated value	50 A
• at AC-51 according to IEC 60947-4-3	38 A
• according to UL 508 rated value	38 A

operational current minimum	500 mA
rate of voltage rise at the thyristor for main contacts maximum permissible	1 000 V/ μ s
blocking voltage at the thyristor for main contacts maximum permissible	1 200 V
reverse current of the thyristor	10 mA
derating temperature	40 °C
surge current resistance rated value	1 150 A
I²t value maximum	6 600 A ² ·s
Control circuit/ Control	
type of voltage of the control supply voltage	AC
control supply voltage 1 at AC	
• at 50 Hz	180 ... 230 V
• at 60 Hz	180 ... 230 V
control supply voltage frequency	
• 1 rated value	45 Hz
• 2 rated value	66 Hz
control supply voltage at AC	
• at 50 Hz full-scale value for signal<0> recognition	40 V
• at 60 Hz full-scale value for signal<0> recognition	180 V
control supply voltage	
• at AC initial value for signal <1> detection	180 V
symmetrical line frequency tolerance	5 Hz
control current at minimum control supply voltage	
• at AC	2 mA
control current at AC rated value	15 mA
ON-delay time	40 ms; additionally max. one half-wave
Auxiliary circuit	
type of switching contact	normally open contact (NO)
number of NC contacts for auxiliary contacts	0
number of NO contacts for auxiliary contacts	0
number of CO contacts for auxiliary contacts	0
Installation/ mounting/ dimensions	
fastening method side-by-side mounting	Yes
fastening method	screw fixing
design of the thread of the screw for securing the equipment	M4
height	95 mm
width	119.5 mm
depth	130 mm
Connections/ Terminals	
product component removable terminal for auxiliary and control circuit	Yes
type of electrical connection	
• for main current circuit	Ring cable lug connection
• for auxiliary and control circuit	screw-type terminals
type of connectable conductor cross-sections	
• for main contacts for JIS cable lug	JIS C 2805 R 2-5, 5,5-5, 8-5, 14-5
• for DIN cable lug for main contacts	DIN 46234 -5-2,5, -5-6, -5-10, -5-16, -5-25
type of connectable conductor cross-sections	
• for auxiliary and control contacts	
— solid	1x (0.5 ... 2.5 mm ²), 2x (0.5 ... 1 mm ²)
— finely stranded with core end processing	1x (0.5 ... 2.5 mm ²), 2x (0.5 ... 1 mm ²)
— finely stranded without core end processing	1x (0.5 ... 2.5 mm ²), 2x (0.5 ... 1 mm ²)
• for AWG cables for auxiliary and control contacts	1x (20 ... 12)
tightening torque	
• for main contacts with screw-type terminals	2 ... 2.5 N·m
• for auxiliary and control contacts with screw-type terminals	0.5 ... 0.6 N·m
tightening torque [lbf·in]	
• for main contacts with screw-type terminals	18 ... 22 lbf·in
• for auxiliary and control contacts with screw-type	7.5 ... 5.3 lbf·in

terminals	
design of the thread of the connection screw	
<ul style="list-style-type: none"> • for main contacts • of the auxiliary and control contacts 	M5 M3
stripped length of the cable	
<ul style="list-style-type: none"> • for main contacts • for auxiliary and control contacts 	10 mm 7 mm

Electrical Safety	
protection class IP on the front according to IEC 60529	IP00

Ambient conditions	
installation altitude at height above sea level maximum	1 000 m
ambient temperature	
<ul style="list-style-type: none"> • during operation • during storage 	-25 ... +60 °C -55 ... +80 °C

Electromagnetic compatibility	
conducted interference	
<ul style="list-style-type: none"> • due to burst according to IEC 61000-4-4 • due to conductor-earth surge according to IEC 61000-4-5 • due to conductor-conductor surge according to IEC 61000-4-5 • due to high-frequency radiation according to IEC 61000-4-6 	2 kV / 5 kHz behavior criterion 2 2 kV behavior criterion 2 1 kV behavior criterion 2 140 dBuV in the frequency range 0.15 ... 80 MHz, behavior criterion 1
electrostatic discharge according to IEC 61000-4-2	4 kV contact discharging / 8 kV air discharging, behavior criterion 2
conducted HF interference emissions according to CISPR11	Class A for industrial environment
field-bound HF interference emission according to CISPR11	Class A for industrial environment

Short-circuit protection, design of the fuse link	
manufacturer's article number <ul style="list-style-type: none"> • of full range R fuse link for semiconductor protection at NH design usable • of full range R fuse link for semiconductor protection at cylindrical design usable • of back-up R fuse link for semiconductor protection at NH design usable • of back-up R fuse link for semiconductor protection at cylindrical design 14 x 51 mm usable • of back-up R fuse link for semiconductor protection at cylindrical design 22 x 58 mm usable 	3NE1817-0 5SE1350: Maximum operating voltage 400 V! 3NE8018-1 3NC1450 3NC2280
manufacturer's article number of the gG fuse at NH design usable <ul style="list-style-type: none"> • up to 460 V 	3NA3812: These fuses have a smaller rated current than the semiconductor relays

Approvals Certificates

General Product Approval	EMV	Test Certificates
    		Type Test Certificates/Test Report

other	Environment
 Confirmation 	Environmental Confirmations

Further information

Information on the packaging
<https://support.industry.siemens.com/cs/ww/en/view/109813875>
 Information for data generation and storage
<https://support.industry.siemens.com/cs/ww/en/view/109995012>
 Information- and Downloadcenter (Catalogs, Brochures,...)
<https://www.siemens.com/ic10>
 Industry Mall (Online ordering system)

<https://mall.industry.siemens.com/mall/en/en/Catalog/product?mlfb=3RF2450-3AB55>

Cax online generator

<https://support.automation.siemens.com/WW/CAXorder/default.aspx?lang=en&mlfb=3RF2450-3AB55>

Service&Support (Manuals, Certificates, Characteristics, FAQs,...)

<https://support.industry.siemens.com/cs/ww/en/ps/3RF2450-3AB55>

Image database (product images, 2D dimension drawings, 3D models, device circuit diagrams, EPLAN macros, ...)

https://www.automation.siemens.com/bilddb/cax_de.aspx?mlfb=3RF2450-3AB55&lang=en

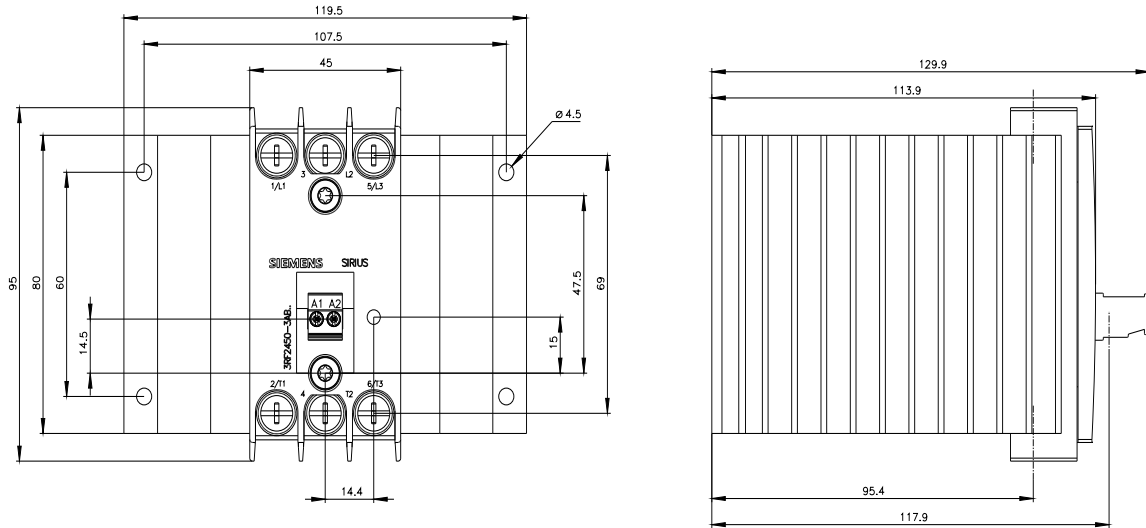

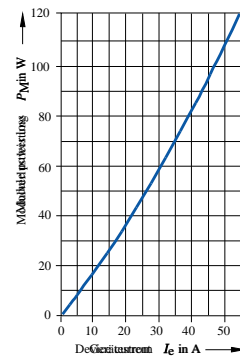
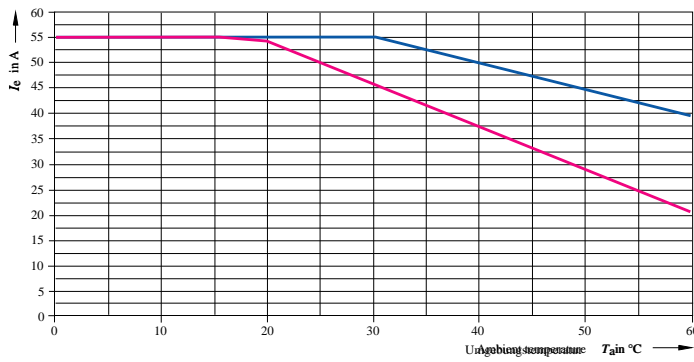
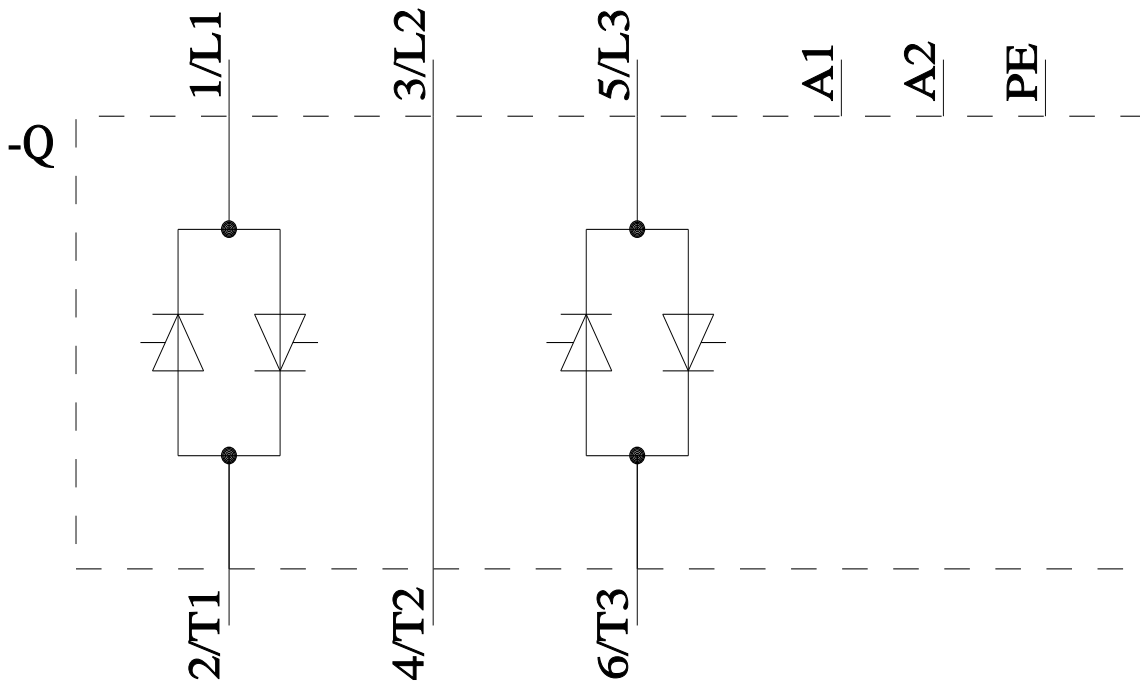

— I_{\max} Thermischer Grenzstrom bei Einzelaufstellung und Dicht-an-Dicht-Montage
— I_{IEC} Strom nach IEC 947-4-3 bei Einzelaufstellung und Dicht-an-Dicht-Montage

last modified:

8/4/2025