



coupling contactor relay, 2 NO + 2 NC, 24 V DC, 0.85-1.85\*Us, screw terminal, frame size S00, suitable for PLC outputs, not expandable with auxiliary switch

product brand name	SIRIUS
product designation	Coupling relay for switching auxiliary circuits
product type designation	3RH2
<b>General technical data</b>	
size of contactor	S00
product extension auxiliary switch	No
power loss [W] for rated value of the current without load current share typical	1.6 W
insulation voltage with degree of pollution 3 at AC rated value	690 V
degree of pollution	3
surge voltage resistance rated value	6 kV
shock resistance at rectangular impulse	
• at DC	10g / 5 ms, 5g / 10 ms
shock resistance with sine pulse	
• at DC	15g / 5 ms, 8g / 10 ms
mechanical service life (operating cycles)	
• of contactor typical	30 000 000
reference code according to IEC 81346-2	K
Substance Prohibitance (Date)	10/01/2009
Weight	0.313 kg
<b>Ambient conditions</b>	
installation altitude at height above sea level maximum	2 000 m
ambient temperature	
• during operation	-25 ... +50 °C
• during storage	-55 ... +80 °C
relative humidity minimum	10 %
relative humidity at 55 °C according to IEC 60068-2-30 maximum	95 %
<b>Environmental footprint</b>	
Environmental Product Declaration (EPD)	Yes
global warming potential [CO2 eq] total	133 kg
global warming potential [CO2 eq] during manufacturing	1.3 kg
global warming potential [CO2 eq] during operation	132 kg
global warming potential [CO2 eq] after end of life	-0.227 kg
<b>Main circuit</b>	
no-load switching frequency	
• at AC	10 000 1/h
• at DC	10 000 1/h
<b>Control circuit/ Control</b>	
type of voltage of the control supply voltage	DC
control supply voltage at DC rated value	24 V

<b>operating range factor control supply voltage rated value of magnet coil at DC</b>	
• initial value	0.85
• full-scale value	1.85
<b>closing power of magnet coil at DC</b>	1.6 W
<b>holding power of magnet coil at DC</b>	1.6 W
<b>closing delay</b>	
• at DC	25 ... 120 ms
<b>opening delay</b>	
• at DC	5 ... 20 ms
<b>arcing time</b>	10 ... 15 ms
<b>Auxiliary circuit</b>	
<b>number of NC contacts for auxiliary contacts</b>	2
• instantaneous contact	2
<b>number of NO contacts for auxiliary contacts</b>	2
• instantaneous contact	2
<b>identification number and letter for switching elements</b>	22 E
operational current at AC-12 maximum	10 A
<b>operational current at AC-15</b>	
• at 230 V rated value	10 A
• at 400 V rated value	3 A
• at 500 V rated value	2 A
• at 690 V rated value	1 A
<b>operational current at 1 current path at DC-12</b>	
• at 24 V rated value	10 A
• at 110 V rated value	3 A
• at 220 V rated value	1 A
• at 440 V rated value	0.3 A
• at 600 V rated value	0.15 A
<b>operational current with 2 current paths in series at DC-12</b>	
• at 24 V rated value	10 A
• at 60 V rated value	10 A
• at 110 V rated value	4 A
• at 220 V rated value	2 A
• at 440 V rated value	1.3 A
• at 600 V rated value	0.65 A
<b>operational current with 3 current paths in series at DC-12</b>	
• at 24 V rated value	10 A
• at 60 V rated value	10 A
• at 110 V rated value	10 A
• at 220 V rated value	3.6 A
• at 440 V rated value	2.5 A
• at 600 V rated value	1.8 A
<b>operating frequency at DC-12 maximum</b>	1 000 1/h
<b>operational current at 1 current path at DC-13</b>	
• at 24 V rated value	10 A
• at 110 V rated value	1 A
• at 220 V rated value	0.3 A
• at 440 V rated value	0.14 A
• at 600 V rated value	0.1 A
<b>operational current with 2 current paths in series at DC-13</b>	
• at 24 V rated value	10 A
• at 60 V rated value	3.5 A
• at 110 V rated value	1.3 A
• at 220 V rated value	0.9 A
• at 440 V rated value	0.2 A
• at 600 V rated value	0.1 A
<b>operational current with 3 current paths in series at DC-13</b>	
• at 24 V rated value	10 A
• at 60 V rated value	4.7 A
• at 110 V rated value	3 A

<ul style="list-style-type: none"> <li>• at 220 V rated value</li> <li>• at 440 V rated value</li> <li>• at 600 V rated value</li> </ul>	<p>1.2 A</p> <p>0.5 A</p> <p>0.26 A</p>
<b>operating frequency at DC-13 maximum</b>	1 000 1/h
<b>contact reliability of auxiliary contacts</b>	1 faulty switching per 100 million (17 V, 1 mA)
<b>UL/CSA ratings</b>	
<b>contact rating of auxiliary contacts according to UL</b>	A600 / Q600
<b>Short-circuit protection</b>	
design of the miniature circuit breaker for short-circuit protection of the auxiliary circuit up to 230 V	C characteristic: 10 A; 0.4 kA
design of the fuse link for short-circuit protection of the auxiliary switch required	gG: 10 A (690 V, 1 kA)
<b>Installation/ mounting/ dimensions</b>	
<b>mounting position</b>	+/-180° rotation possible on vertical mounting surface; can be tilted forward and backward by +/- 22.5° on vertical mounting surface
<b>fastening method</b>	screw and snap-on mounting onto 35 mm DIN rail
<b>height</b>	57.5 mm
<b>width</b>	45 mm
<b>depth</b>	73 mm
<b>required spacing</b>	
<ul style="list-style-type: none"> <li>• with side-by-side mounting <ul style="list-style-type: none"> <li>— forwards</li> <li>— upwards</li> <li>— downwards</li> <li>— at the side</li> </ul> </li> <li>• for grounded parts <ul style="list-style-type: none"> <li>— forwards</li> <li>— upwards</li> <li>— at the side</li> <li>— downwards</li> </ul> </li> <li>• for live parts <ul style="list-style-type: none"> <li>— forwards</li> <li>— upwards</li> <li>— downwards</li> <li>— at the side</li> </ul> </li> </ul>	<p>10 mm</p> <p>10 mm</p> <p>10 mm</p> <p>0 mm</p> <p>10 mm</p> <p>10 mm</p> <p>6 mm</p> <p>10 mm</p> <p>10 mm</p> <p>10 mm</p> <p>10 mm</p> <p>6 mm</p>
<b>Connections/ Terminals</b>	
type of electrical connection for auxiliary and control circuit	screw-type terminals
<b>type of connectable conductor cross-sections</b>	
<ul style="list-style-type: none"> <li>• for auxiliary contacts <ul style="list-style-type: none"> <li>— solid or stranded</li> <li>— finely stranded with core end processing</li> </ul> </li> <li>• for AWG cables for auxiliary contacts</li> </ul>	<p>2x (0.5 ... 1.5 mm<sup>2</sup>), 2x (0.75 ... 2.5 mm<sup>2</sup>), 2x 4 mm<sup>2</sup></p> <p>2x (0.5 ... 1.5 mm<sup>2</sup>), 2x (0.75 ... 2.5 mm<sup>2</sup>)</p> <p>2x (20 ... 16), 2x (18 ... 14), 2x 12</p>
<b>Safety related data</b>	
<b>product function</b>	
<ul style="list-style-type: none"> <li>• positively driven operation according to IEC 60947-5-1</li> <li>• suitable for safety function</li> </ul>	<p>Yes</p> <p>Yes</p>
suitability for use safety-related switching OFF	Yes
<b>service life maximum</b>	20 a
<b>proportion of dangerous failures</b>	
<ul style="list-style-type: none"> <li>• with low demand rate according to SN 31920</li> <li>• with high demand rate according to SN 31920</li> </ul>	<p>40 %</p> <p>73 %</p>
<b>B10 value with high demand rate according to SN 31920</b>	1 000 000; With 0.3 x I <sub>e</sub>
<b>failure rate [FIT] with low demand rate according to SN 31920</b>	100 FIT
<b>ISO 13849</b>	
<b>device type according to ISO 13849-1</b>	3
<b>overdimensioning according to ISO 13849-2 necessary</b>	Yes
<b>IEC 61508</b>	
<b>safety device type according to IEC 61508-2</b>	Type A
<b>Electrical Safety</b>	
<b>protection class IP on the front according to IEC 60529</b>	IP20
<b>touch protection on the front according to IEC 60529</b>	finger-safe, for vertical contact from the front

Approvals Certificates

General Product Approval



EMV	Functional Safety	Test Certificates	Maritime application
-----	-------------------	-------------------	----------------------



[Type Examination Certificate](#)

[Special Test Certificate](#)

[Type Test Certificates/Test Report](#)



Maritime application	other
----------------------	-------



[Miscellaneous](#)

other	Railway	Dangerous goods	Environment
-------	---------	-----------------	-------------



[Confirmation](#)

[Special Test Certificate](#)

[Transport Information](#)



[Environmental Confirmations](#)

Further information

Information on the packaging

<https://support.industry.siemens.com/cs/ww/en/view/109813875>

Information for data generation and storage

<https://support.industry.siemens.com/cs/ww/en/view/109995012>

Information- and Downloadcenter (Catalogs, Brochures,...)

<https://www.siemens.com/ic10>

Industry Mall (Online ordering system)

<https://mall.industry.siemens.com/mall/en/en/Catalog/product?mlfb=3RH2122-1MB40-0KT0>

Cax online generator

<https://support.automation.siemens.com/WW/CAXorder/default.aspx?lang=en&mlfb=3RH2122-1MB40-0KT0>

Service&Support (Manuals, Certificates, Characteristics, FAQs,...)

<https://support.industry.siemens.com/cs/ww/en/ps/3RH2122-1MB40-0KT0>

Image database (product images, 2D dimension drawings, 3D models, device circuit diagrams, EPLAN macros, ...)

[https://www.automation.siemens.com/bilddb/cax\\_de.aspx?mlfb=3RH2122-1MB40-0KT0&lang=en](https://www.automation.siemens.com/bilddb/cax_de.aspx?mlfb=3RH2122-1MB40-0KT0&lang=en)

Characteristic: Tripping characteristics, I<sup>2</sup>t, Let-through current

<https://support.industry.siemens.com/cs/ww/en/ps/3RH2122-1MB40-0KT0/char>

Further characteristics (e.g. electrical endurance, switching frequency)

<https://www.automation.siemens.com/bilddb/index.aspx?view=Search&mlfb=3RH2122-1MB40-0KT0&objecttype=14&gridview=view1>

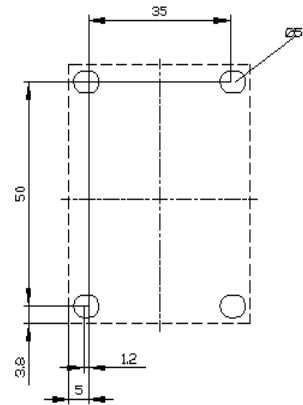





last modified:

9/5/2025 