



Fail-safe direct-on-line starter High Feature; Electronic switching; Electronic overload protection up to 0.25 kW / 400 V; Adjustment range 0.3 ... 1 A; PROFinergy; Option: 3DI/LC module

product brand name	SIMATIC
product category	Motor starter
product designation	Direct-on-line starter
product type designation	ET 200SP
General technical data	
equipment version according to IEC 60947-4-2	3
product function	Fail-safe direct-on-line starter
<ul style="list-style-type: none"> on-site operation intrinsic device protection remote firmware update for power supply reverse polarity protection 	Yes Yes Yes Yes
power loss [W] for rated value of the current	0 W
<ul style="list-style-type: none"> at AC in hot operating state per pole 	
insulation voltage rated value	500 V
degree of pollution	2
overvoltage category	III
surge voltage resistance rated value	6 kV
maximum permissible voltage for protective separation	500 V
<ul style="list-style-type: none"> between main and auxiliary circuit 	
consumed current maximum	140 mA
shock resistance	6g / 11 ms
vibration resistance	15 mm to 6 Hz; 2g to 500 Hz
operating frequency maximum	1 1/s
mechanical service life (operating cycles) of the main contacts typical	30 000 000
type of coordination	1
utilization category	AC-53a: 1 A: (8-0,7: 70-32)
<ul style="list-style-type: none"> according to IEC 60947-4-2 	
reference code according to IEC 81346-2	Q
Substance Prohibitance (Date)	04/15/2016
SVHC substance name	Lead - 7439-92-1 Lead monoxide (lead oxide) - 1317-36-8 2,2',6,6'-tetrabromo-4,4'-isopropylidenediphenol - 79-94-7 6,6'-di-tert-butyl-2,2'-methylenedi-p-cresol - 119-47-1
Weight	0.427 kg
product function	
<ul style="list-style-type: none"> direct start reverse starting 	Yes No
product component motor brake output	No
product function short circuit protection	Yes
design of short-circuit protection	fuse

maximum short-circuit current breaking capacity (Icu)	
<ul style="list-style-type: none"> • at 400 V rated value • at 500 V rated value • at 500 V according to UL 60947 rated value 	<p>55 kA</p> <p>55 kA</p> <p>100 kA</p>
maximum short-circuit current breaking capacity (Icu) in the IT network	
<ul style="list-style-type: none"> • at 400 V rated value • at 500 V rated value 	<p>55 kA</p> <p>55 kA</p>
Electromagnetic compatibility	
EMC emitted interference according to IEC 60947-1	class A
EMC immunity according to IEC 60947-1	Class A
conducted interference	
<ul style="list-style-type: none"> • due to burst according to IEC 61000-4-4 • due to conductor-earth surge according to IEC 61000-4-5 • due to conductor-conductor surge according to IEC 61000-4-5 • due to high-frequency radiation according to IEC 61000-4-6 	<p>3 kV</p> <p>4 kV</p> <p>2 kV</p> <p>Class A</p>
field-based interference according to IEC 61000-4-3	20 V/m
electrostatic discharge according to IEC 61000-4-2	8 kV air discharge
conducted HF interference emissions according to CISPR11	Class A for industrial environment
field-bound HF interference emission according to CISPR11	Class A for industrial environment
Safety related data	
product function suitable for safety function	Yes
suitability for use	
<ul style="list-style-type: none"> • safety-related switching on • safety-related switching OFF 	<p>No</p> <p>Yes</p>
safe state	Load circuit open
test wear-related service life necessary	Yes
function test interval maximum	0.083 a
diagnostics test interval by internal test function maximum	600 s
stop category according to IEC 60204-1	0
proportion of dangerous failures with high demand rate according to SN 31920	50 %
B10 value with high demand rate according to SN 31920	1 000 000
IEC 62061	
Safety Integrity Level (SIL) according to IEC 62061	SIL 3
ISO 13849	
performance level (PL) according to ISO 13849-1	PL e
category according to ISO 13849-1	4
device type according to ISO 13849-1	1
overdimensioning according to ISO 13849-2 necessary	No
IEC 61508	
Safety Integrity Level (SIL) according to IEC 61508	SIL 3
safety device type according to IEC 61508-2	Type B
PFH according to IEC 61508 relating to SIL	6E-9 1/h; for switching frequency 30/h
PFDavg with low demand rate according to IEC 61508	9E-7; for switching frequency 30/h
Safe failure fraction (SFF)	99.5 %
hardware fault tolerance according to IEC 61508	1
T1 value	
<ul style="list-style-type: none"> • of service life according to IEC 61508 	20 a
Electrical Safety	
touch protection against electrical shock	finger-safe
protection class IP on the front according to IEC 60529	IP20
touch protection on the front according to IEC 60529	finger-safe
ATEX	
Safety Integrity Level (SIL) according to IEC 61508 relating to ATEX	SIL 1
hardware fault tolerance according to IEC 61508 relating to ATEX	1
Main circuit	
number of poles for main current circuit	3

design of the switching contact	Hybrid
adjustable current response value current of the current-dependent overload release	0.3 ... 1 A
minimum load [%]	50 %; from smallest adjustable rated current
type of the motor protection	solid-state
operating voltage rated value	48 ... 500 V
relative symmetrical tolerance of the operating voltage	10 %
operating frequency 1 rated value	50 Hz
operating frequency 2 rated value	60 Hz
relative symmetrical tolerance of the operating frequency	5 %
relative positive tolerance of the operating frequency	5 %
relative negative tolerance of the operating frequency	5 %
operational current at AC at 400 V rated value	1 A
ampacity when starting maximum	10 A
operating power for 3-phase motors at 400 V at 50 Hz	0.09 ... 0.25 kW

Inputs/ Outputs

number of digital inputs	5
<ul style="list-style-type: none"> note safety-related 	4 via 3DI/LC module 1
type of input characteristic	Type 1 in accordance with EN 61131-2
input voltage at digital input at DC rated value	24 V
input current at digital input for signal <1> typical	0 A
address space memory of address range	
<ul style="list-style-type: none"> of the inputs of the outputs 	4 byte 2 byte

Supply voltage

type of voltage of the supply voltage	DC
supply voltage 1 at DC rated value	
<ul style="list-style-type: none"> minimum permissible maximum permissible 	20.4 V 28.8 V
supply voltage at DC rated value	24 V
consumed current for rated value of supply voltage	
<ul style="list-style-type: none"> in standby mode of operation during operation at switching on of motor 	50 mA 50 mA 140 mA
power loss [W] for rated value of supply voltage	
<ul style="list-style-type: none"> in switching state OFF with bypass circuit in switching state ON with bypass circuit 	1.2 W 3.4 W
inrush current peak at 24 V	25 A; Observe the manual for group configuration
duration of inrush current peak at 24 V	0.14 ms

Response times

ON-delay time	35 ms
OFF-delay time	35 ... 50 ms
OFF-delay time with safety-related request	
<ul style="list-style-type: none"> when switched off via control inputs maximum when switched off via supply voltage maximum 	55 ms 120 ms

Power Electronics

operational current	
<ul style="list-style-type: none"> at 40 °C rated value at 50 °C rated value at 55 °C rated value at 60 °C rated value 	1 A 1 A 1 A 1 A

Installation/ mounting/ dimensions

mounting position	Vertical, horizontal (observe derating)
fastening method	pluggable in BaseUnit
height	142 mm
width	30 mm
depth	150 mm
required spacing with side-by-side mounting	
<ul style="list-style-type: none"> upwards downwards 	50 mm 50 mm

Ambient conditions	
installation altitude at height above sea level maximum	4 000 m; For derating see manual
ambient temperature	
• during operation	-25 ... +60 °C; For derating see manual
• during storage	-40 ... +70 °C
• during transport	-40 ... +70 °C
environmental category during operation according to IEC 60721	3K6 (no formation of ice, no condensation), 3C3 (no salt mist), 3S2 (sand must not get into the devices)
relative humidity during operation	10 ... 95 %
air pressure according to SN 31205	900 ... 1 060 hPa

Communication/ Protocol	
protocol is supported	
• PROFIBUS DP protocol	Yes
• PROFINET protocol	Yes
product function bus communication	Yes
protocol is supported AS-Interface protocol	No
product function	
• supports PROFinergy measured values	Yes
• supports PROFinergy shutdown	Yes
type of electrical connection of the communication interface	Plug contact to Base Unit

Connections/ Terminals	
type of electrical connection	
• 1 for digital input signals	Pluggable module - accessory
• 2 for digital input signals	Plug contact to Base Unit
type of electrical connection	
• for main energy infeed	Plug contact to Base Unit
• for load-side outgoing feeder	Plug contact to Base Unit
• for supply voltage line-side	Plug contact to Base Unit
wire length for motor unshielded maximum	200 m

UL/CSA ratings	
full-load current (FLA) for 3-phase AC motor at 480 V rated value	1 A
current with locked rotor (LRA) for 3-phase AC motor at 480 V rated value	8 A
operating voltage at AC at 60 Hz according to CSA and UL rated value	480 V

Approvals Certificates	
General Product Approval	EMV



EMV	For use in hazardous locations	Functional Safety	Test Certificates	Maritime application
-----	--------------------------------	-------------------	-------------------	----------------------

[KC](#)



[Type Examination Certificate](#)

[Type Test Certificates/Test Report](#)



Maritime application	other	Dangerous goods	Environment
----------------------	-------	-----------------	-------------



[Confirmation](#)

[Transport Information](#)

[Environmental Confirmations](#)

Industrial Communication



Profibus

Further information

Information on the packaging

<https://support.industry.siemens.com/cs/ww/en/view/109813875>

Information for data generation and storage

<https://support.industry.siemens.com/cs/ww/en/view/109995012>

Information- and Downloadcenter (Catalogs, Brochures,...)

<https://www.siemens.com/ic10>

Industry Mall (Online ordering system)

<https://mall.industry.siemens.com/mall/en/en/Catalog/product?mlfb=3RK1308-0CB00-0CP0>

Cax online generator

<https://support.automation.siemens.com/WW/CAXorder/default.aspx?lang=en&mlfb=3RK1308-0CB00-0CP0>

Service&Support (Manuals, Certificates, Characteristics, FAQs,...)

<https://support.industry.siemens.com/cs/ww/en/ps/3RK1308-0CB00-0CP0>

Image database (product images, 2D dimension drawings, 3D models, device circuit diagrams, EPLAN macros, ...)

https://www.automation.siemens.com/bilddb/cax_de.aspx?mlfb=3RK1308-0CB00-0CP0&lang=en

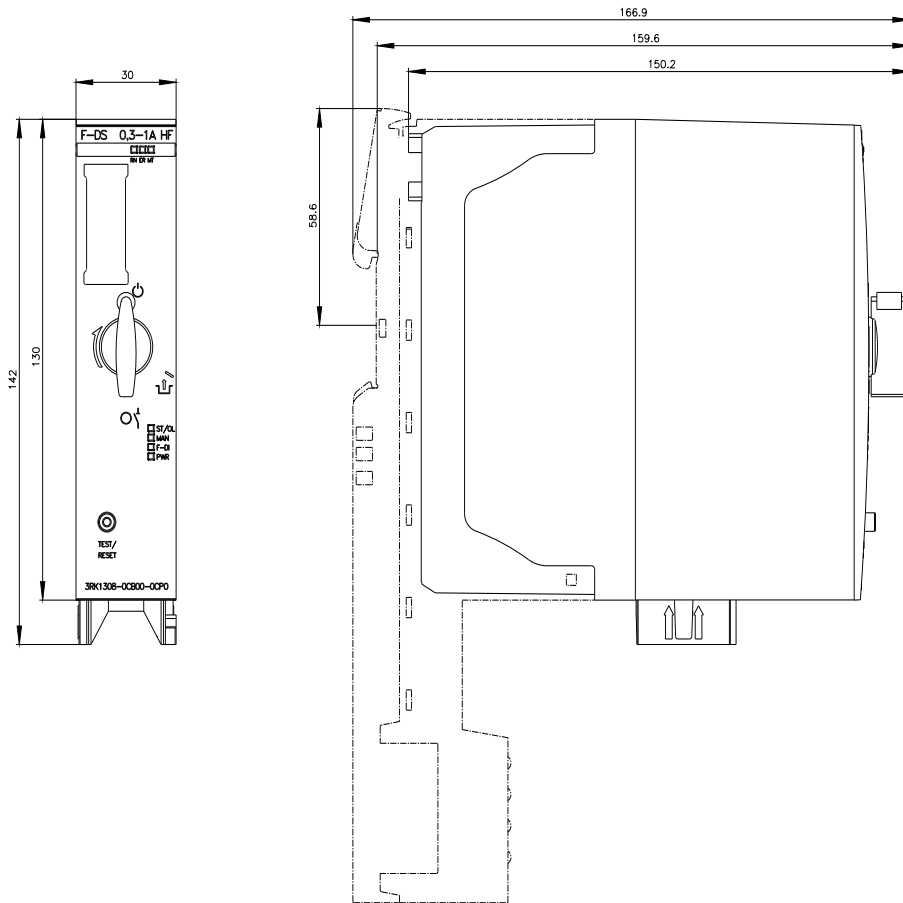

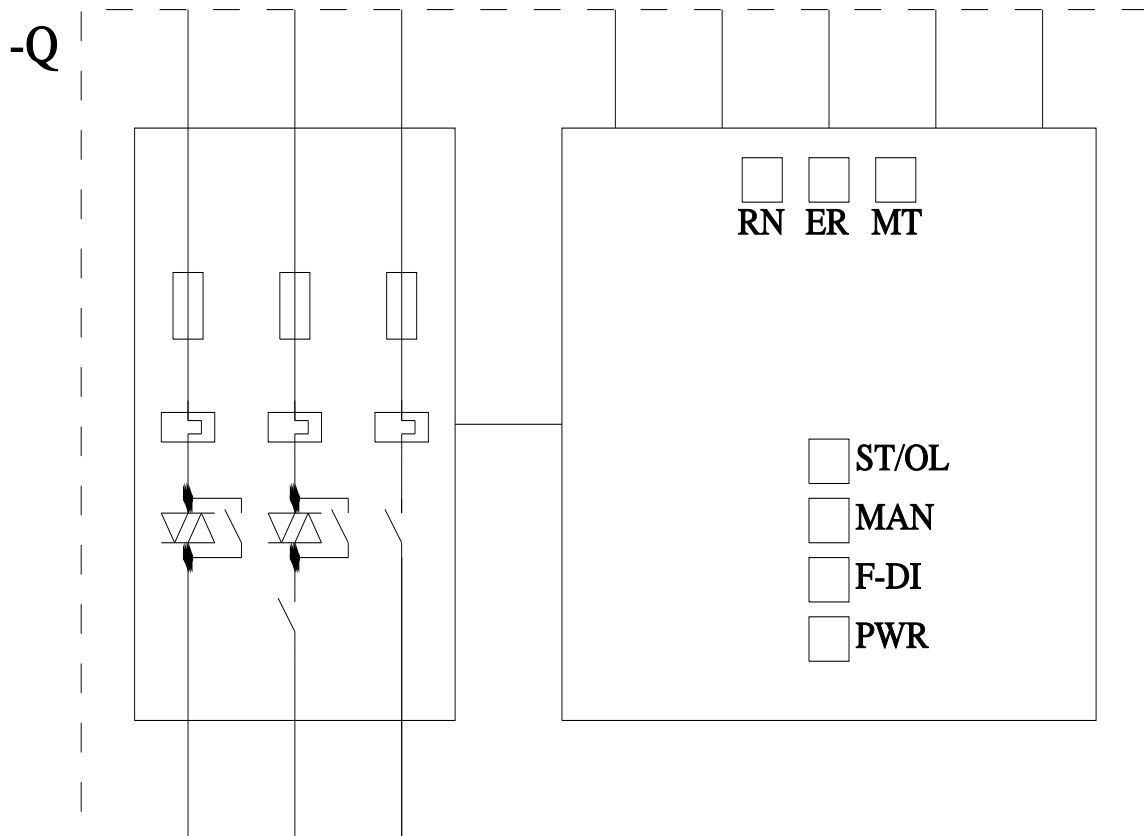

last modified:

9/6/2025