



SIRIUS motor starter M200D AS-i communication: AS-Interface reversing starter standard mechanical switching AC-3, 5.5 kW / 400 V 1.5 A...12.00 A electronic overload protection thermistor: thermoclick / PTC with brake contact 180 V DC 4 DI / 1 DO AS-i Han Q4/2 - Han Q8/0 with manual on-site operation and keyswitch

product brand name	SIRIUS
product designation	Motor starters
design of the product	reversing starter
product type designation	M200D
product function	
• on-site operation	Yes
• control circuit interface to parallel wiring	No
insulation voltage rated value	500 V
degree of pollution	3
surge voltage resistance rated value	6 000 V
maximum permissible voltage for protective separation	
• between main and auxiliary circuit	400 V
• between control and auxiliary circuit	24 V
shock resistance	12g / 11 ms
vibration resistance	7 mm / 2g
mechanical service life (operating cycles) of the main contacts typical	10 000 000
type of coordination	1
Substance Prohibitance (Date)	07/01/2006
SVHC substance name	Lead - 7439-92-1 Lead monoxide (lead oxide) - 1317-36-8 2,2',6,6'-tetrabromo-4,4'-isopropylidenediphenol - 79-94-7 6,6'-di-tert-butyl-2,2'-methylenedi-p-cresol - 119-47-1
Weight	4.362 kg
product function	
• direct start	No
• reverse starting	Yes
product component motor brake output	Yes
product feature	
• brake control with 230 V AC	No
• brake control with 400 V AC	No
• brake control with 24 V DC	No
• brake control with 180 V DC	Yes
• brake control with 500 V DC	No
product extension braking module for brake control	No
product function short circuit protection	Yes
design of short-circuit protection	circuit-breakers
maximum short-circuit current breaking capacity (Icu)	
• at 400 V rated value	50 000 A
• at 500 V rated value	50 000 A
EMC emitted interference according to IEC 60947-1	CISPR11, ambience A (industrial sector)

EMC immunity according to IEC 60947-1	corresponds to degree of severity 3, ambience A (industrial sector)
conducted interference	
<ul style="list-style-type: none"> • due to burst according to IEC 61000-4-4 • due to conductor-earth surge according to IEC 61000-4-5 • due to conductor-conductor surge according to IEC 61000-4-5 	2 kV network connection / 1 kV control connection 2 kV 1 kV
Safety related data	
proportion of dangerous failures	
<ul style="list-style-type: none"> • with low demand rate according to SN 31920 • with high demand rate according to SN 31920 	50 % 75 %
B10 value with high demand rate according to SN 31920	1 000 000
failure rate [FIT] with low demand rate according to SN 31920	100 FIT
IEC 61508	
T1 value for proof test interval or service life according to IEC 61508	20 a
Electrical Safety	
touch protection against electrical shock	finger-safe
Main circuit	
number of poles for main current circuit	3
design of the switching contact	electromechanical
adjustable current response value current of the current-dependent overload release	1.5 ... 12 A
type of the motor protection	full motor protection
operating voltage rated value	200 ... 440 V
operational current	
<ul style="list-style-type: none"> • at AC at 400 V rated value • at AC-3 at 400 V rated value 	12 A 12 A
operating power	
<ul style="list-style-type: none"> • at AC-3 <ul style="list-style-type: none"> — at 400 V rated value — at 500 V rated value • at AC-3e <ul style="list-style-type: none"> — at 400 V rated value — at 500 V rated value 	5.5 kW 5 500 W 6 kW 5.5 kW
product function	
<ul style="list-style-type: none"> • digital inputs parameterizable • digital outputs parameterizable 	Yes Yes
number of digital inputs	4
number of sockets	
<ul style="list-style-type: none"> • for digital output signals • for digital input signals 	1 4
number of digital outputs	1
Supply voltage	
type of voltage of the supply voltage	DC
supply voltage 1 at DC	24 V
supply voltage 1 at DC rated value	30 V
<ul style="list-style-type: none"> • minimum permissible • maximum permissible 	26.5 V 31.6 V
Control circuit/ Control	
type of voltage of the control supply voltage	DC
control supply voltage at DC rated value	20.4 ... 28.8 V
control supply voltage 1 at DC rated value	24 V
control supply voltage 1 at DC rated value	20.4 ... 28.8 V
control supply voltage 1 at DC	20.4 ... 28.8 V
control current at DC	
<ul style="list-style-type: none"> • in standby mode of operation • during operation 	100 mA 0.6 A
power loss [W] in auxiliary and control circuit	
<ul style="list-style-type: none"> • in switching state OFF with bypass circuit • in switching state ON with bypass circuit 	2.0736 W 4.1184 W
Response times	

ON-delay time	85 ms
OFF-delay time	65 ms
mounting position	vertical, horizontal, flat
mounting position recommended	horizontal
fastening method	screw fixing
height	215 mm
width	294 mm
depth	159 mm
Ambient conditions	
installation altitude at height above sea level maximum	2 000 m
ambient temperature	
• during operation	-25 ... +55 °C
• during storage	-40 ... +70 °C
• during transport	-40 ... +70 °C
relative humidity during operation	10 ... 95 %
protocol is supported	
• PROFIBUS DP protocol	No
• PROFINET protocol	No
design of the interface	
• AS-Interface protocol	Yes
• PROFINET protocol	No
• PROFIBUS DP protocol	No
product function bus communication	Yes
protocol is supported AS-Interface protocol	Yes
product function control circuit interface with IO link	No
type of electrical connection of the communication interface	M12 plug
type of electrical connection	
• for main current circuit	plug according to ISO 23570, HAN Q4/2
• for auxiliary and control circuit	connector
type of electrical connection	
• 1 for digital input signals	M12 socket
• 1 for digital output signals	M12 socket
• 2 for digital input signals	M12 socket
• 3 for digital input signals	M12 socket
• 4 for digital input signals	M12 socket
type of electrical connection	
• at the manufacturer-specific device interface	optical interface
• for device addressing	M12 plug
• for supply voltage line-side	M12 plug
full-load current (FLA) for 3-phase AC motor at 480 V rated value	11 A
yielded mechanical performance [hp]	
• for 3-phase AC motor	
— at 220/230 V rated value	3 hp
— at 460/480 V rated value	7.5 hp
— at 575/600 V rated value	10 hp
operating voltage at AC at 60 Hz according to CSA and UL rated value	600 V

Approvals Certificates

General Product Approval

EMV



Test Certificates

other

Dangerous goods

Environment

Industrial Communication



Further information

Information on the packaging

<https://support.industry.siemens.com/cs/ww/en/view/109813875>

Information for data generation and storage

<https://support.industry.siemens.com/cs/ww/en/view/109995012>

Information- and Downloadcenter (Catalogs, Brochures,...)

<https://www.siemens.com/ic10>

Industry Mall (Online ordering system)

<https://mall.industry.siemens.com/mall/en/en/Catalog/product?mlfb=3RK1325-6LS41-3AA5>

Cax online generator

<https://support.automation.siemens.com/WW/CAXorder/default.aspx?lang=en&mlfb=3RK1325-6LS41-3AA5>

Service&Support (Manuals, Certificates, Characteristics, FAQs,...)

<https://support.industry.siemens.com/cs/ww/en/ps/3RK1325-6LS41-3AA5>

Image database (product images, 2D dimension drawings, 3D models, device circuit diagrams, EPLAN macros, ...)

https://www.automation.siemens.com/bilddb/cax_de.aspx?mlfb=3RK1325-6LS41-3AA5&lang=en



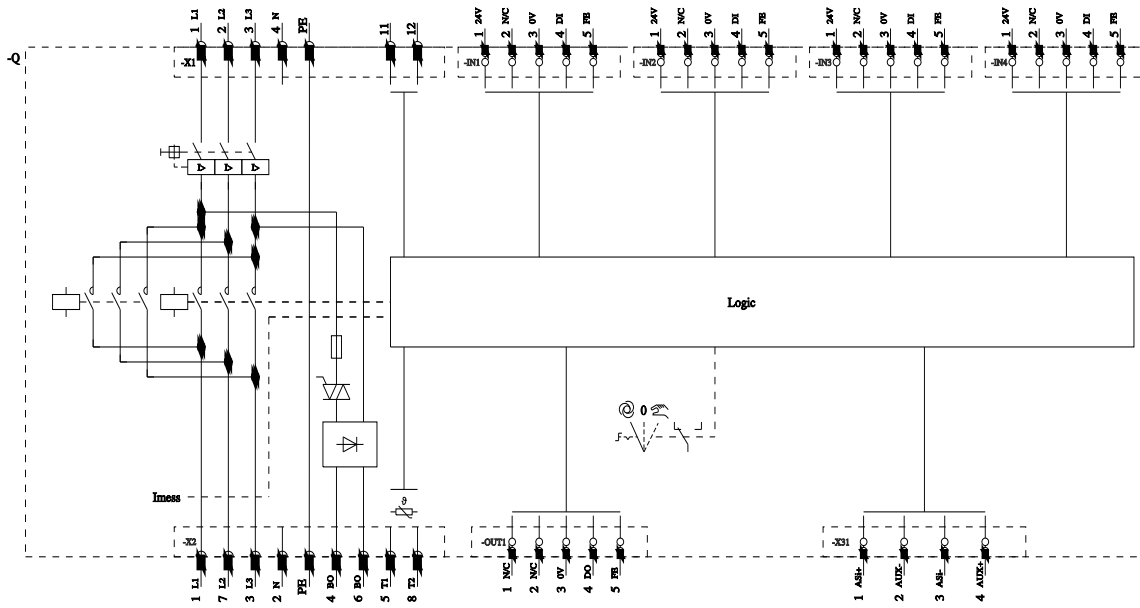

last modified:

4/2/2025 