



power contactor AC-1 400 A / 690 V / 40 °C 3-pole, drive: without auxiliary contacts  
2 NO + 2 NC main circuit: busbar control and auxiliary circuit: screw terminal

<b>product brand name</b>	SIRIUS
<b>product designation</b>	Contacteur
<b>product type designation</b>	3RT14
<b>General technical data</b>	
<b>size of contactor</b>	S10
<b>product extension</b>	
• function module for communication	No
• auxiliary switch	Yes
<b>power loss [W] for rated value of the current</b>	
• at AC in hot operating state	105.6 W
• at AC in hot operating state per pole	35.2 W
<b>type of calculation of power loss depending on pole</b>	quadratic
<b>insulation voltage</b>	
• of main circuit with degree of pollution 3 rated value	1 000 V
• of auxiliary circuit with degree of pollution 3 rated value	500 V
<b>surge voltage resistance</b>	
• of main circuit rated value	8 kV
• of auxiliary circuit rated value	6 kV
<b>shock resistance at rectangular impulse</b>	
• at AC	8,5g / 5 ms, 4,2g / 10 ms
• at DC	8,5g / 5 ms, 4,2g / 10 ms
<b>shock resistance with sine pulse</b>	
• at AC	13,4g / 5 ms, 6,5g / 10 ms
• at DC	13,4g / 5 ms, 6,5g / 10 ms
<b>mechanical service life (operating cycles)</b>	
• of contactor typical	10 000 000
• of the contactor with added electronically optimized auxiliary switch block typical	5 000 000
• of the contactor with added auxiliary switch block typical	10 000 000
<b>reference code according to IEC 81346-2</b>	Q
<b>Substance Prohibitance (Date)</b>	05/01/2012
<b>SVHC substance name</b>	Lead - 7439-92-1
<b>Weight</b>	5.957 kg
<b>Ambient conditions</b>	
installation altitude at height above sea level maximum	2 000 m
<b>ambient temperature</b>	
• during operation	-25 ... +60 °C
• during storage	-55 ... +80 °C
<b>relative humidity minimum</b>	10 %
<b>relative humidity at 55 °C according to IEC 60068-2-30 maximum</b>	95 %

## Main circuit

number of poles for main current circuit	3
number of NO contacts for main contacts	3
number of NC contacts for main contacts	0
type of voltage for main current circuit	AC
<b>operational current</b>	
<ul style="list-style-type: none"> <li>● at AC-1 <ul style="list-style-type: none"> <li>— up to 690 V at ambient temperature 40 °C rated value</li> <li>— up to 690 V at ambient temperature 55 °C rated value</li> <li>— up to 690 V at ambient temperature 60 °C rated value</li> </ul> </li> <li>● at AC-3 <ul style="list-style-type: none"> <li>— at 400 V rated value</li> <li>— at 690 V rated value</li> </ul> </li> </ul>	<p>400 A</p> <p>380 A</p> <p>380 A</p> <p>138 A</p> <p>138 A</p>
minimum cross-section in main circuit at maximum AC-1 rated value	240 mm <sup>2</sup>
<b>operational current</b>	
<ul style="list-style-type: none"> <li>● at 1 current path at DC-1 <ul style="list-style-type: none"> <li>— at 24 V rated value</li> <li>— at 60 V rated value</li> <li>— at 110 V rated value</li> <li>— at 220 V rated value</li> <li>— at 440 V rated value</li> <li>— at 600 V rated value</li> </ul> </li> <li>● with 2 current paths in series at DC-1 <ul style="list-style-type: none"> <li>— at 24 V rated value</li> <li>— at 60 V rated value</li> <li>— at 110 V rated value</li> <li>— at 220 V rated value</li> <li>— at 440 V rated value</li> <li>— at 600 V rated value</li> </ul> </li> <li>● with 3 current paths in series at DC-1 <ul style="list-style-type: none"> <li>— at 24 V rated value</li> <li>— at 60 V rated value</li> <li>— at 110 V rated value</li> <li>— at 220 V rated value</li> <li>— at 440 V rated value</li> <li>— at 600 V rated value</li> </ul> </li> <li>● at 1 current path at DC-3 at DC-5 <ul style="list-style-type: none"> <li>— at 24 V rated value</li> <li>— at 60 V rated value</li> <li>— at 110 V rated value</li> <li>— at 220 V rated value</li> <li>— at 440 V rated value</li> <li>— at 600 V rated value</li> </ul> </li> <li>● with 2 current paths in series at DC-3 at DC-5 <ul style="list-style-type: none"> <li>— at 24 V rated value</li> <li>— at 60 V rated value</li> <li>— at 110 V rated value</li> <li>— at 220 V rated value</li> <li>— at 440 V rated value</li> <li>— at 600 V rated value</li> </ul> </li> <li>● with 3 current paths in series at DC-3 at DC-5 <ul style="list-style-type: none"> <li>— at 24 V rated value</li> <li>— at 60 V rated value</li> <li>— at 110 V rated value</li> <li>— at 220 V rated value</li> <li>— at 440 V rated value</li> <li>— at 600 V rated value</li> </ul> </li> </ul>	<p>380 A</p> <p>380 A</p> <p>33 A</p> <p>3.8 A</p> <p>0.9 A</p> <p>0.6 A</p> <p>380 A</p> <p>380 A</p> <p>380 A</p> <p>380 A</p> <p>4 A</p> <p>2 A</p> <p>380 A</p> <p>380 A</p> <p>380 A</p> <p>380 A</p> <p>11 A</p> <p>5.2 A</p> <p>380 A</p> <p>11 A</p> <p>3 A</p> <p>0.6 A</p> <p>0.18 A</p> <p>0.125 A</p> <p>380 A</p> <p>380 A</p> <p>380 A</p> <p>2.5 A</p> <p>0.65 A</p> <p>0.37 A</p> <p>380 A</p> <p>380 A</p> <p>380 A</p> <p>380 A</p> <p>1.4 A</p> <p>0.75 A</p>
no-load switching frequency	

<ul style="list-style-type: none"> <li>• at AC</li> </ul>	2 000 1/h
<ul style="list-style-type: none"> <li>• at DC</li> </ul>	2 000 1/h
operating frequency at AC-1 maximum	600 1/h
<b>Control circuit/ Control</b>	
<b>closing delay</b>	
<ul style="list-style-type: none"> <li>• at AC</li> </ul>	30 ... 95 ms
<ul style="list-style-type: none"> <li>• at DC</li> </ul>	30 ... 95 ms
<b>opening delay</b>	
<ul style="list-style-type: none"> <li>• at AC</li> </ul>	40 ... 80 ms
<ul style="list-style-type: none"> <li>• at DC</li> </ul>	40 ... 80 ms
<b>arcing time</b>	10 ... 15 ms
<b>control version of the switch operating mechanism</b>	Without operating mechanism
<b>Auxiliary circuit</b>	
<b>number of NC contacts for auxiliary contacts</b>	2
<ul style="list-style-type: none"> <li>• attachable</li> </ul>	4
<ul style="list-style-type: none"> <li>• instantaneous contact</li> </ul>	2
<b>number of NO contacts for auxiliary contacts</b>	2
<ul style="list-style-type: none"> <li>• attachable</li> </ul>	4
<ul style="list-style-type: none"> <li>• instantaneous contact</li> </ul>	2
operational current at AC-12 maximum	10 A
<b>operational current at AC-15</b>	
<ul style="list-style-type: none"> <li>• at 230 V rated value</li> </ul>	6 A
<ul style="list-style-type: none"> <li>• at 400 V rated value</li> </ul>	3 A
<ul style="list-style-type: none"> <li>• at 500 V rated value</li> </ul>	2 A
<ul style="list-style-type: none"> <li>• at 690 V rated value</li> </ul>	1 A
<b>operational current at DC-13</b>	
<ul style="list-style-type: none"> <li>• at 24 V rated value</li> </ul>	10 A
<ul style="list-style-type: none"> <li>• at 48 V rated value</li> </ul>	2 A
<ul style="list-style-type: none"> <li>• at 60 V rated value</li> </ul>	2 A
<ul style="list-style-type: none"> <li>• at 110 V rated value</li> </ul>	1 A
<ul style="list-style-type: none"> <li>• at 125 V rated value</li> </ul>	0.9 A
<ul style="list-style-type: none"> <li>• at 220 V rated value</li> </ul>	0.3 A
<ul style="list-style-type: none"> <li>• at 600 V rated value</li> </ul>	0.1 A
<b>contact reliability of auxiliary contacts</b>	1 faulty switching per 100 million (17 V, 1 mA)
<b>Short-circuit protection</b>	
design of the miniature circuit breaker for short-circuit protection of the auxiliary circuit up to 230 V	C characteristic: 10 A; 0.4 kA
<b>design of the fuse link</b>	
<ul style="list-style-type: none"> <li>• for short-circuit protection of the main circuit <ul style="list-style-type: none"> <li>— with type of coordination 1 required</li> <li>— with type of coordination 2 required</li> </ul> </li> </ul>	gG: 500 A (690 V, 100 kA) gR: 500 A (690 V, 100 kA)
<ul style="list-style-type: none"> <li>• for short-circuit protection of the auxiliary switch required</li> </ul>	gG: 10 A (500 V, 1 kA)
<b>Installation/ mounting/ dimensions</b>	
<b>mounting position</b>	with vertical mounting surface +/-90° rotatable, with vertical mounting surface +/- 22.5° tiltable to the front and back
fastening method side-by-side mounting	Yes
<b>fastening method</b>	screw fixing
<b>height</b>	210 mm
<b>width</b>	145 mm
<b>depth</b>	202 mm
<b>required spacing</b>	
<ul style="list-style-type: none"> <li>• with side-by-side mounting <ul style="list-style-type: none"> <li>— forwards</li> <li>— upwards</li> <li>— downwards</li> <li>— at the side</li> </ul> </li> </ul>	20 mm 10 mm 10 mm 0 mm
<ul style="list-style-type: none"> <li>• for grounded parts <ul style="list-style-type: none"> <li>— forwards</li> <li>— upwards</li> <li>— at the side</li> <li>— downwards</li> </ul> </li> </ul>	20 mm 10 mm 10 mm 10 mm

- for live parts
  - forwards 20 mm
  - upwards 10 mm
  - downwards 10 mm
  - at the side 10 mm

### Connections/ Terminals

<b>type of electrical connection</b>	
<ul style="list-style-type: none"> <li>• for main current circuit</li> <li>• for auxiliary and control circuit</li> <li>• at contactor for auxiliary contacts</li> <li>• of magnet coil</li> </ul>	Connection bar screw-type terminals Screw-type terminals Screw-type terminals
<b>width of connection bar</b>	25 mm
<b>thickness of connection bar</b>	6 mm
<b>diameter of holes</b>	11 mm
<b>number of holes</b>	1
<b>type of connectable conductor cross-sections</b>	
<ul style="list-style-type: none"> <li>• for AWG cables for main contacts</li> </ul>	2/0 ... 500 kcmil
<b>connectable conductor cross-section for main contacts</b>	
<ul style="list-style-type: none"> <li>• solid or stranded</li> <li>• stranded</li> </ul>	70 ... 240 mm <sup>2</sup> 70 ... 240 mm <sup>2</sup>
<b>connectable conductor cross-section for auxiliary contacts</b>	
<ul style="list-style-type: none"> <li>• solid or stranded</li> <li>• finely stranded with core end processing</li> </ul>	0.5 ... 4 mm <sup>2</sup> 0.5 ... 2.5 mm <sup>2</sup>
<b>type of connectable conductor cross-sections</b>	
<ul style="list-style-type: none"> <li>• for auxiliary contacts               <ul style="list-style-type: none"> <li>— solid</li> <li>— solid or stranded</li> <li>— finely stranded with core end processing</li> </ul> </li> <li>• for AWG cables for auxiliary contacts</li> </ul>	2x (0.5 ... 1.5 mm <sup>2</sup> ), 2x (0.75 ... 2.5 mm <sup>2</sup> ), max. 2x (0.75 ... 4 mm <sup>2</sup> ) 2x (0,5 ... 1,5 mm <sup>2</sup> ), 2x (0,75 ... 2,5 mm <sup>2</sup> ), max. 2x (0,75 ... 4 mm <sup>2</sup> ) 2x (0.5 ... 1.5 mm <sup>2</sup> ), 2x (0.75 ... 2.5 mm <sup>2</sup> ) 2x (20 ... 16), 2x (18 ... 14), 1x 12
<b>AWG number as coded connectable conductor cross section for auxiliary contacts</b>	18 ... 14

### Safety related data

<b>product function</b>	
<ul style="list-style-type: none"> <li>• mirror contact according to IEC 60947-4-1</li> <li>• positively driven operation according to IEC 60947-5-1</li> </ul>	Yes No
suitability for use safety-related switching OFF	No
<b>service life maximum</b>	20 a

### Electrical Safety

<b>protection class IP on the front according to IEC 60529</b>	IP00; IP20 with box terminal/cover
<b>touch protection on the front according to IEC 60529</b>	finger-safe, for vertical contact from the front with box terminal/cover

### Approvals Certificates

General Product Approval

EMV



Functional Safety

Test Certificates

Maritime application

[Type Examination Certificate](#)

[Type Test Certificates/Test Report](#)

[Special Test Certificate](#)



Maritime application

other

Railway



[Confirmation](#)

[Miscellaneous](#)

[Special Test Certificate](#)

## Environment

[Environmental Confirmations](#)

## Further information

Information on the packaging

<https://support.industry.siemens.com/cs/ww/en/view/109813875>

Information for data generation and storage

<https://support.industry.siemens.com/cs/ww/en/view/109995012>

Information- and Downloadcenter (Catalogs, Brochures,...)

<https://www.siemens.com/ic10>

Industry Mall (Online ordering system)

<https://mall.industry.siemens.com/mall/en/en/Catalog/product?mlfb=3RT1466-6LA06>

Cax online generator

<https://support.automation.siemens.com/WW/CAXorder/default.aspx?lang=en&mlfb=3RT1466-6LA06>

Service&Support (Manuals, Certificates, Characteristics, FAQs,...)

<https://support.industry.siemens.com/cs/ww/en/ps/3RT1466-6LA06>

Image database (product images, 2D dimension drawings, 3D models, device circuit diagrams, EPLAN macros, ...)

[https://www.automation.siemens.com/bilddb/cax\\_de.aspx?mlfb=3RT1466-6LA06&lang=en](https://www.automation.siemens.com/bilddb/cax_de.aspx?mlfb=3RT1466-6LA06&lang=en)

Characteristic: Tripping characteristics, I<sup>2</sup>t, Let-through current

<https://support.industry.siemens.com/cs/ww/en/ps/3RT1466-6LA06/char>

Further characteristics (e.g. electrical endurance, switching frequency)

<https://www.automation.siemens.com/bilddb/index.aspx?view=Search&mlfb=3RT1466-6LA06&objecttype=14&gridview=view1>

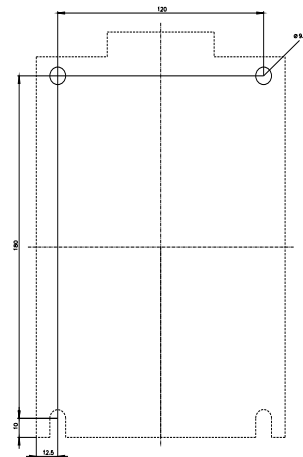
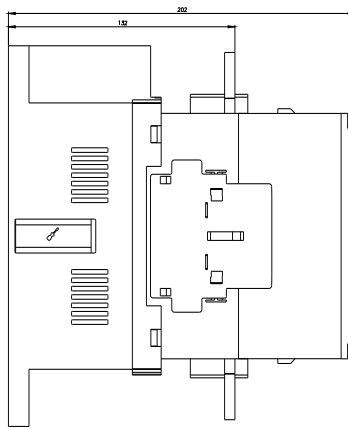
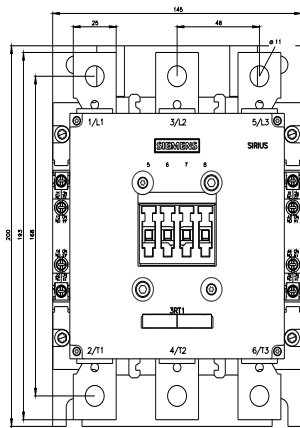

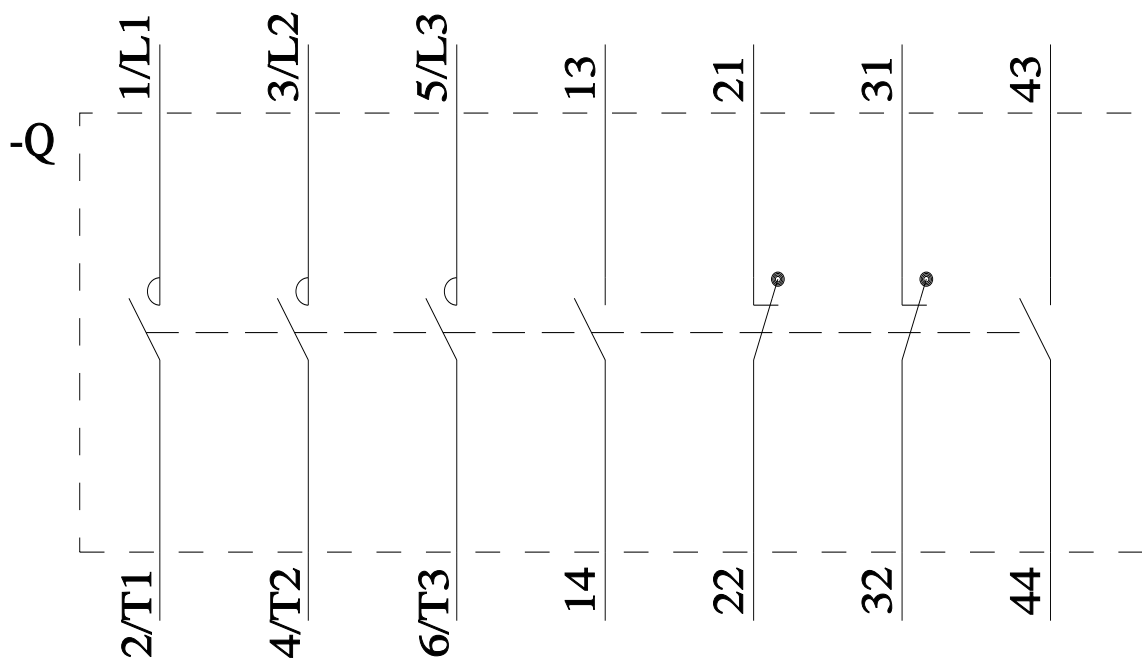

last modified:

4/10/2025 