



capacitor contactor, AC-6b 50 kVA_r, / 400 V, 3-pole, 20-33 V AC/DC, 50/60 Hz, with integrated varistor, auxiliary contacts: 2 NC, screw terminal, size: S2

product brand name	SIRIUS
product designation	capacitor contactors
product type designation	3RT26
General technical data	
size of contactor	S2
product extension auxiliary switch	Yes
power loss [W] for rated value of the current	
• at AC in hot operating state per pole	4 W
• without load current share typical	2.4 W
type of calculation of power loss depending on pole	quadratic
insulation voltage	
• of main circuit with degree of pollution 3 rated value	690 V
• of auxiliary circuit with degree of pollution 3 rated value	690 V
surge voltage resistance	
• of main circuit rated value	6 kV
• of auxiliary circuit rated value	6 kV
maximum permissible voltage for protective separation between coil and main contacts according to EN 60947-1	400 V
shock resistance at rectangular impulse	
• at AC	6.8g / 5 ms, 4g / 10 ms
• at DC	6,8g / 5 ms, 4g / 10 ms
shock resistance with sine pulse	
• at AC	10.6g / 5 ms, 6.2g / 10 ms
• at DC	10,6g / 5 ms, 6,2g / 10 ms
mechanical service life (operating cycles)	
• of the contactor with added auxiliary switch block typical	3 000 000
electrical endurance (operating cycles)	200 000
reference code according to IEC 81346-2	Q
Substance Prohibitance (Date)	05/01/2014
SVHC substance name	Lead - 7439-92-1 Lead monoxide (lead oxide) - 1317-36-8 2-methyl-1-(4-methylthiophenyl)-2-morpholinopropan-1-one - 71868-10-5 Melamine - 108-78-1
Weight	1.105 kg
Ambient conditions	
installation altitude at height above sea level maximum	2 000 m
ambient temperature	
• during operation	-25 ... +60 °C
• during storage	-55 ... +80 °C
relative humidity minimum	10 %
relative humidity at 55 °C according to IEC 60068-2-30 maximum	95 %

Environmental footprint	
Environmental Product Declaration(EPD)	Yes
global warming potential [CO2 eq] total	106 kg
global warming potential [CO2 eq] during manufacturing	2.47 kg
global warming potential [CO2 eq] during operation	104 kg
global warming potential [CO2 eq] after end of life	-0.226 kg
Main circuit	
number of poles for main current circuit	3
number of NO contacts for main contacts	3
number of NC contacts for main contacts	0
operational current at AC-6b at 690 V at ambient temperature 60 °C rated value	72.2 A
operating reactive power at AC-6b	
• at 230 V at 50/60 Hz at ambient temperature 60 °C rated value	10 ... 29 kvar
• at 400 V at 50/60 Hz at ambient temperature 60 °C rated value	17 ... 50 kvar
• at 500 V at 50/60 Hz at ambient temperature 60 °C rated value	21 ... 63 kvar
• at 690 V at 50/60 Hz at ambient temperature 60 °C rated value	29 ... 86 kvar
no-load switching frequency	
• at AC	500 1/h
• at DC	500 1/h
operating frequency at AC-6b	
• at 230 V maximum	100 1/h
• at 240 V maximum	100 1/h
• at 400 V maximum	100 1/h
• at 480 V maximum	60 1/h
• at 500 V maximum	55 1/h
• at 600 V maximum	40 1/h
• at 690 V maximum	30 1/h
Control circuit/ Control	
type of voltage	AC/DC
type of voltage of the control supply voltage	AC/DC
control supply voltage at AC	
• at 50 Hz rated value	20 ... 33 V
• at 60 Hz rated value	20 ... 33 V
control supply voltage frequency	
• 1 rated value	50 Hz
• 2 rated value	60 Hz
control supply voltage at DC rated value	20 ... 33 V
operating range factor control supply voltage rated value of magnet coil at DC	
• initial value	0.8
• full-scale value	1.1
operating range factor control supply voltage rated value of magnet coil at AC	
• at 50 Hz	0.8 ... 1.1
• at 60 Hz	0.8 ... 1.1
inrush current peak	30 A
duration of inrush current peak	30 µs
locked-rotor current mean value	6.5 A
locked-rotor current peak	12 A
duration of locked-rotor current	230 ms
holding current mean value	105 mA
apparent pick-up power of magnet coil at AC	110 VA
inductive power factor with closing power of the coil	0.95
apparent holding power of magnet coil at AC	2.5 VA
inductive power factor with the holding power of the coil	0.95
closing power of magnet coil at DC	70 W
holding power of magnet coil at DC	1.5 W
closing delay	

<ul style="list-style-type: none"> • at AC • at DC 	30 ... 110 ms
opening delay	
<ul style="list-style-type: none"> • at AC • at DC 	30 ... 55 ms
arcing time	10 ... 20 ms
control version of the switch operating mechanism	Standard A1 - A2
Auxiliary circuit	
number of NC contacts for auxiliary contacts	2
<ul style="list-style-type: none"> • attachable • instantaneous contact 	1 2
number of NO contacts for auxiliary contacts	0
<ul style="list-style-type: none"> • attachable • instantaneous contact 	1 0
operational current of auxiliary contacts at AC-12 maximum	10 A
operational current of auxiliary contacts at AC-15	
<ul style="list-style-type: none"> • at 230 V • at 400 V • at 690 V 	6 A 3 A 0 A
operational current of auxiliary contacts at DC-13	
<ul style="list-style-type: none"> • at 24 V • at 60 V • at 110 V • at 125 V • at 220 V 	6 A 2 A 1 A 0.9 A 0.3 A
contact reliability of auxiliary contacts	0.00000001
UL/CSA ratings	
contact rating of auxiliary contacts according to UL	A600 / Q600
Short-circuit protection	
design of the miniature circuit breaker for short-circuit protection of the auxiliary circuit up to 230 V	C characteristic: 10 A; 0.4 kA
design of the fuse link	
<ul style="list-style-type: none"> • for short-circuit protection of the main circuit with type of coordination 1 required • for short-circuit protection of the auxiliary switch required 	gG: 160 A (690 V, 50 kA) gG: 10 A (690 V, 1 kA)
Installation/ mounting/ dimensions	
mounting position	+/-180° rotation possible on vertical mounting surface; can be tilted forward and backward by +/- 22.5° on vertical mounting surface
fastening method	screw and snap-on mounting onto 35 mm DIN rail according to DIN EN 50022
height	114 mm
width	65 mm
depth	130 mm
required spacing	
<ul style="list-style-type: none"> • with side-by-side mounting at the side • for grounded parts at the side 	10 mm 10 mm
Connections/ Terminals	
type of electrical connection	
<ul style="list-style-type: none"> • for main current circuit • for auxiliary and control circuit • at contactor for auxiliary contacts • of magnet coil 	screw-type terminals screw-type terminals Screw-type terminals Screw-type terminals
type of connectable conductor cross-sections for main contacts	
<ul style="list-style-type: none"> • solid • stranded • solid or stranded • finely stranded with core end processing 	2x (1 ... 16 mm ²) 2x (10 ... 35 mm ²), 1x (10 ... 50 mm ²) 2x (1 ... 35 mm ²), 1x (1 ... 50 mm ²) 2x (1 ... 25 mm ²), 1x (1 ... 35 mm ²)
type of connectable conductor cross-sections	
<ul style="list-style-type: none"> • for auxiliary contacts <ul style="list-style-type: none"> — solid — solid or stranded — finely stranded with core end processing 	2x (0.5 ... 1.5 mm ²), 2x (0.75 ... 2.5 mm ²), 2x 4 mm ² 2x (0.5 ... 1.5 mm ²), 2x (0.75 ... 2.5 mm ²), 2x 4 mm ² 2x (0.5 ... 1.5 mm ²), 2x (0.75 ... 2.5 mm ²)

<ul style="list-style-type: none"> for AWG cables for auxiliary contacts 	2x (20 ... 16), 2x (18 ... 14), 2x 12
type of minimum connectable cross-sections for main contacts at AC-6b <ul style="list-style-type: none"> at 40 °C at 60 °C 	1x 35 mm ² 1x 50 mm ²
AWG number as coded connectable conductor cross section for main contacts	18 ... 0

Safety related data

product function <ul style="list-style-type: none"> mirror contact according to IEC 60947-4-1 positively driven operation according to IEC 60947-5-1 	No No
---	----------

Electrical Safety

protection class IP on the front according to IEC 60529	IP20
touch protection on the front according to IEC 60529	finger-safe, for vertical contact from the front

Approvals Certificates

General Product Approval



KC



EMV	Test Certificates	Maritime application	other
-----	-------------------	----------------------	-------



[Type Test Certificates/Test Report](#)



[Confirmation](#)

Dangerous goods	Environment
-----------------	-------------

[Transport Information](#)



[Environmental Confirmations](#)

Further information

Information on the packaging

<https://support.industry.siemens.com/cs/ww/en/view/109813875>

Information for data generation and storage

<https://support.industry.siemens.com/cs/ww/en/view/109995012>

Information- and Downloadcenter (Catalogs, Brochures,...)

<https://www.siemens.com/ic10>

Industry Mall (Online ordering system)

<https://mall.industry.siemens.com/mall/en/en/Catalog/product?mlfb=3RT2636-1NB35>

Cax online generator

<https://support.automation.siemens.com/WW/CAXorder/default.aspx?lang=en&mlfb=3RT2636-1NB35>

Service&Support (Manuals, Certificates, Characteristics, FAQs,...)

<https://support.industry.siemens.com/cs/ww/en/ps/3RT2636-1NB35>

Image database (product images, 2D dimension drawings, 3D models, device circuit diagrams, EPLAN macros, ...)

https://www.automation.siemens.com/bilddb/cax_de.aspx?mlfb=3RT2636-1NB35&lang=en

Characteristic: Tripping characteristics, I²t, Let-through current

<https://support.industry.siemens.com/cs/ww/en/ps/3RT2636-1NB35/char>

Further characteristics (e.g. electrical endurance, switching frequency)

<https://www.automation.siemens.com/bilddb/index.aspx?view=Search&mlfb=3RT2636-1NB35&objecttype=14&gridview=view1>

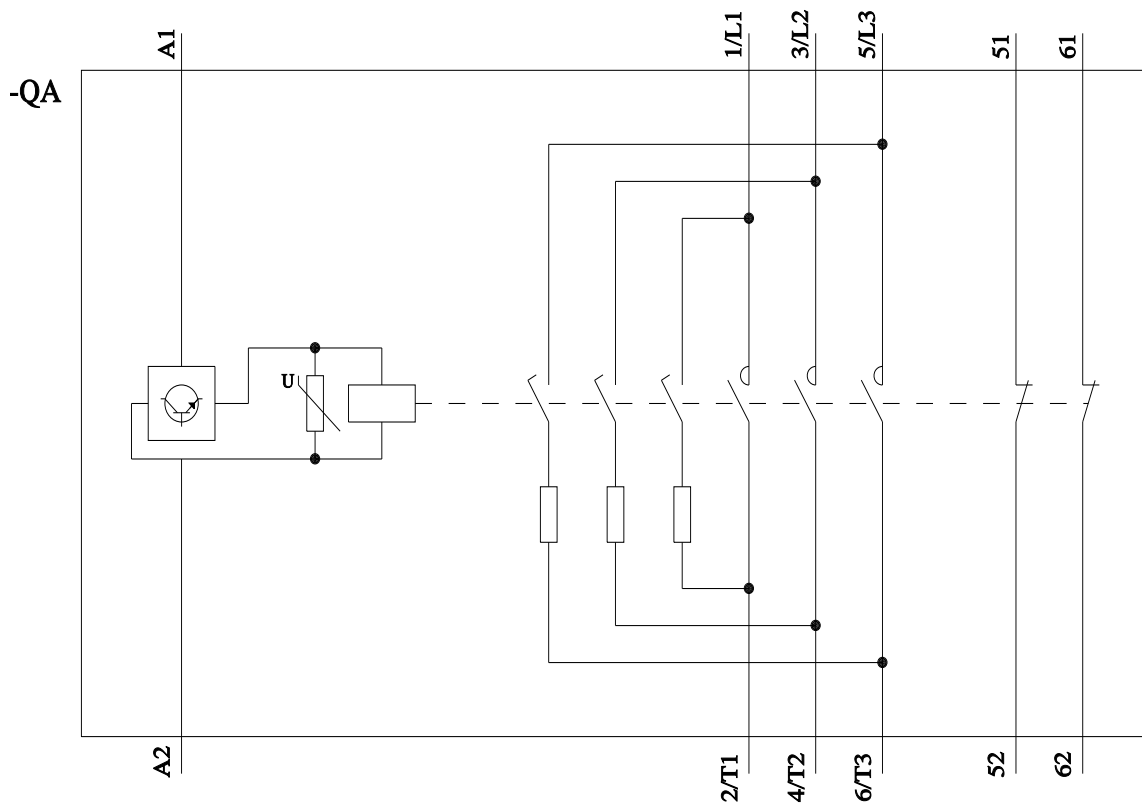
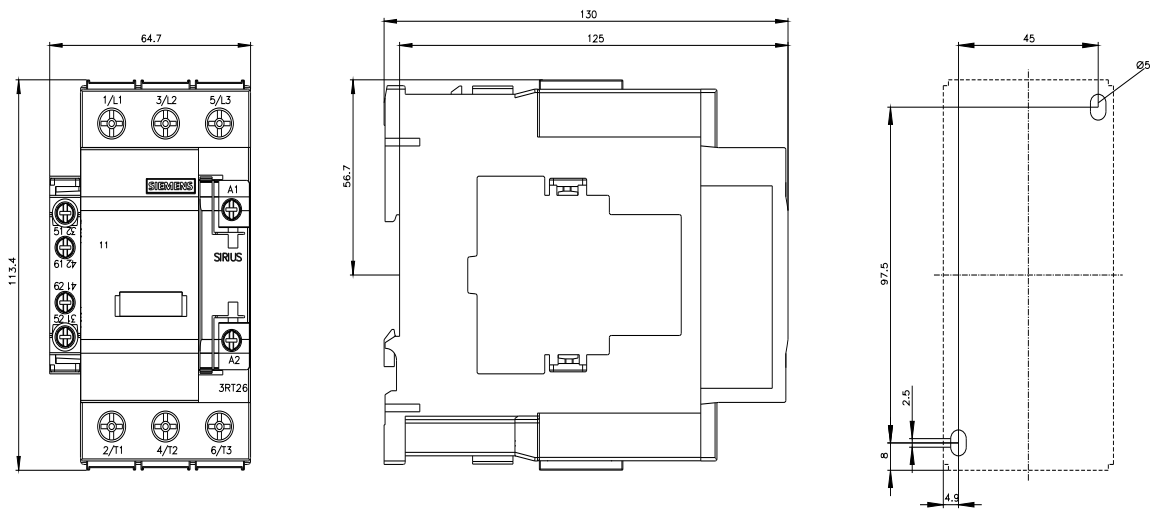

last modified:

11/11/2025

