



capacitor contactor, AC-6b 75 kVA<sub>r</sub>, / 400 V, 3-pole, 175-280 V AC/DC, 50/60 Hz, with integrated varistor, auxiliary contacts: 2 NC, screw terminal, size: S2

product brand name	SIRIUS
product designation	capacitor contactors
product type designation	3RT26
<b>General technical data</b>	
size of contactor	S2
product extension auxiliary switch	Yes
power loss [W] for rated value of the current	
• at AC in hot operating state per pole	3.8 W
• without load current share typical	2.4 W
type of calculation of power loss depending on pole	quadratic
insulation voltage	
• of main circuit with degree of pollution 3 rated value	690 V
• of auxiliary circuit with degree of pollution 3 rated value	690 V
surge voltage resistance	
• of main circuit rated value	6 kV
• of auxiliary circuit rated value	6 kV
maximum permissible voltage for protective separation between coil and main contacts according to EN 60947-1	400 V
shock resistance at rectangular impulse	
• at AC	6.8g / 5 ms, 4g / 10 ms
• at DC	6,8g / 5 ms, 4g / 10 ms
shock resistance with sine pulse	
• at AC	10.6g / 5 ms, 6.2g / 10 ms
mechanical service life (operating cycles)	
• of the contactor with added auxiliary switch block typical	3 000 000
electrical endurance (operating cycles)	150 000
reference code according to IEC 81346-2	Q
Substance Prohibitance (Date)	05/01/2014
SVHC substance name	Lead - 7439-92-1 Lead monoxide (lead oxide) - 1317-36-8
Weight	1.106 kg
<b>Ambient conditions</b>	
installation altitude at height above sea level maximum	2 000 m
ambient temperature	
• during operation	-25 ... +60 °C
• during storage	-55 ... +80 °C
relative humidity minimum	10 %
relative humidity at 55 °C according to IEC 60068-2-30 maximum	95 %
<b>Environmental footprint</b>	
Environmental Product Declaration (EPD)	Yes

global warming potential [CO2 eq] total	106 kg
global warming potential [CO2 eq] during manufacturing	2.47 kg
global warming potential [CO2 eq] during operation	104 kg
global warming potential [CO2 eq] after end of life	-0.226 kg

### Main circuit

<b>number of poles for main current circuit</b>	3
<b>number of NO contacts for main contacts</b>	3
<b>number of NC contacts for main contacts</b>	0
operational current at AC-6b at 690 V at ambient temperature 60 °C rated value	108 A
<b>operating reactive power at AC-6b</b>	
• at 230 V at 50/60 Hz at ambient temperature 60 °C rated value	14 ... 43 kvar
• at 400 V at 50/60 Hz at ambient temperature 60 °C rated value	25 ... 75 kvar
• at 500 V at 50/60 Hz at ambient temperature 60 °C rated value	31 ... 94 kvar
• at 690 V at 50/60 Hz at ambient temperature 60 °C rated value	43 ... 129 kvar
<b>no-load switching frequency</b>	
• at AC	500 1/h
• at DC	500 1/h
<b>operating frequency at AC-6b</b>	
• at 230 V maximum	100 1/h
• at 240 V maximum	100 1/h
• at 400 V maximum	80 1/h
• at 480 V maximum	50 1/h
• at 500 V maximum	45 1/h
• at 600 V maximum	32 1/h
• at 690 V maximum	25 1/h

### Control circuit/ Control

<b>type of voltage</b>	AC/DC
<b>type of voltage of the control supply voltage</b>	AC/DC
<b>control supply voltage at AC</b>	
• at 50 Hz rated value	175 ... 280 V
• at 60 Hz rated value	175 ... 280 V
<b>control supply voltage frequency</b>	
• 1 rated value	50 Hz
• 2 rated value	60 Hz
<b>control supply voltage at DC rated value</b>	175 ... 280 V
<b>operating range factor control supply voltage rated value of magnet coil at DC</b>	
• initial value	0.8
• full-scale value	1.1
<b>operating range factor control supply voltage rated value of magnet coil at AC</b>	
• at 50 Hz	0.8 ... 1.1
• at 60 Hz	0.8 ... 1.1
<b>inrush current peak</b>	25 A
<b>duration of inrush current peak</b>	10 µs
<b>locked-rotor current mean value</b>	0.58 A
<b>locked-rotor current peak</b>	1.5 A
<b>duration of locked-rotor current</b>	230 ms
<b>holding current mean value</b>	10 mA
<b>apparent pick-up power of magnet coil at AC</b>	110 VA
<b>inductive power factor with closing power of the coil</b>	0.95
<b>apparent holding power of magnet coil at AC</b>	2.5 VA
<b>inductive power factor with the holding power of the coil</b>	0.95
<b>closing power of magnet coil at DC</b>	70 W
<b>holding power of magnet coil at DC</b>	1.5 W
<b>closing delay</b>	
• at AC	30 ... 110 ms
• at DC	30 ... 110 ms

<b>opening delay</b>	
• at AC	30 ... 55 ms
• at DC	30 ... 55 ms
<b>arcing time</b>	10 ... 20 ms
<b>control version of the switch operating mechanism</b>	Standard A1 - A2
<b>Auxiliary circuit</b>	
<b>number of NC contacts for auxiliary contacts</b>	2
• attachable	1
• instantaneous contact	2
<b>number of NO contacts for auxiliary contacts</b>	0
• attachable	1
• instantaneous contact	0
<b>operational current of auxiliary contacts at AC-12 maximum</b>	10 A
<b>operational current of auxiliary contacts at AC-15</b>	
• at 230 V	6 A
• at 400 V	3 A
• at 690 V	0 A
<b>operational current of auxiliary contacts at DC-13</b>	
• at 24 V	6 A
• at 60 V	2 A
• at 110 V	1 A
• at 125 V	0.9 A
• at 220 V	0.3 A
<b>contact reliability of auxiliary contacts</b>	0.00000001
<b>UL/CSA ratings</b>	
<b>contact rating of auxiliary contacts according to UL</b>	A600 / Q600
<b>Short-circuit protection</b>	
design of the miniature circuit breaker for short-circuit protection of the auxiliary circuit up to 230 V	C characteristic: 10 A; 0.4 kA
<b>design of the fuse link</b>	
• for short-circuit protection of the main circuit with type of coordination 1 required	gG: 200 A (690 V, 50 kA)
• for short-circuit protection of the auxiliary switch required	gG: 10 A (690 V, 1 kA)
<b>Installation/ mounting/ dimensions</b>	
<b>mounting position</b>	+/-180° rotation possible on vertical mounting surface; can be tilted forward and backward by +/- 22.5° on vertical mounting surface
<b>fastening method</b>	screw and snap-on mounting onto 35 mm DIN rail according to DIN EN 50022
<b>height</b>	114 mm
<b>width</b>	65 mm
<b>depth</b>	130 mm
<b>required spacing</b>	
• with side-by-side mounting at the side	10 mm
• for grounded parts at the side	10 mm
<b>Connections/ Terminals</b>	
<b>type of electrical connection</b>	
• for main current circuit	screw-type terminals
• for auxiliary and control circuit	screw-type terminals
• at contactor for auxiliary contacts	Screw-type terminals
• of magnet coil	Screw-type terminals
<b>type of connectable conductor cross-sections for main contacts</b>	
• solid	2x (1 ... 16 mm <sup>2</sup> )
• stranded	2x (10 ... 35 mm <sup>2</sup> ), 1x (10 ... 50 mm <sup>2</sup> )
• solid or stranded	2x (1 ... 35 mm <sup>2</sup> ), 1x (1 ... 50 mm <sup>2</sup> )
• finely stranded with core end processing	2x (1 ... 25 mm <sup>2</sup> ), 1x (1 ... 35 mm <sup>2</sup> )
<b>type of connectable conductor cross-sections</b>	
• for auxiliary contacts	
— solid	2x (0.5 ... 1.5 mm <sup>2</sup> ), 2x (0.75 ... 2.5 mm <sup>2</sup> ), 2x 4 mm <sup>2</sup>
— solid or stranded	2x (0.5 ... 1.5 mm <sup>2</sup> ), 2x (0.75 ... 2.5 mm <sup>2</sup> ), 2x 4 mm <sup>2</sup>
— finely stranded with core end processing	2x (0.5 ... 1.5 mm <sup>2</sup> ), 2x (0.75 ... 2.5 mm <sup>2</sup> )
• for AWG cables for auxiliary contacts	2x (20 ... 16), 2x (18 ... 14), 2x 12
<b>type of minimum connectable cross-sections for main contacts at AC-6b</b>	

- at 40 °C
- at 60 °C

1x 50 mm<sup>2</sup>  
2x 35 mm<sup>2</sup>

**AWG number as coded connectable conductor cross section for main contacts**

18 ... 0

#### Safety related data

**product function**

- mirror contact according to IEC 60947-4-1
- positively driven operation according to IEC 60947-5-1

No  
No

Electrical Safety

**protection class IP on the front according to IEC 60529**

IP20

**touch protection on the front according to IEC 60529**

finger-safe, for vertical contact from the front

#### Approvals Certificates

General Product Approval



[KC](#)



EMV

Test Certificates

Maritime application

other



[Type Test Certificates/Test Report](#)



[Confirmation](#)



Dangerous goods

Environment

[Transport Information](#)



[Environmental Confirmations](#)

#### Further information

Information on the packaging

<https://support.industry.siemens.com/cs/ww/en/view/109813875>

Information for data generation and storage

<https://support.industry.siemens.com/cs/ww/en/view/109995012>

Information- and Downloadcenter (Catalogs, Brochures,...)

<https://www.siemens.com/ic10>

Industry Mall (Online ordering system)

<https://mall.industry.siemens.com/mall/en/en/Catalog/product?mlfb=3RT2637-1NP35>

Cax online generator

<https://support.automation.siemens.com/WW/CAXorder/default.aspx?lang=en&mlfb=3RT2637-1NP35>

Service&Support (Manuals, Certificates, Characteristics, FAQs,...)

<https://support.industry.siemens.com/cs/ww/en/ps/3RT2637-1NP35>

Image database (product images, 2D dimension drawings, 3D models, device circuit diagrams, EPLAN macros, ...)

[https://www.automation.siemens.com/bilddb/cax\\_de.aspx?mlfb=3RT2637-1NP35&lang=en](https://www.automation.siemens.com/bilddb/cax_de.aspx?mlfb=3RT2637-1NP35&lang=en)

Characteristic: Tripping characteristics, I<sub>t</sub>, Let-through current

<https://support.industry.siemens.com/cs/ww/en/ps/3RT2637-1NP35/char>

Further characteristics (e.g. electrical endurance, switching frequency)

<https://www.automation.siemens.com/bilddb/index.aspx?view=Search&mlfb=3RT2637-1NP35&objecttype=14&gridview=view1>

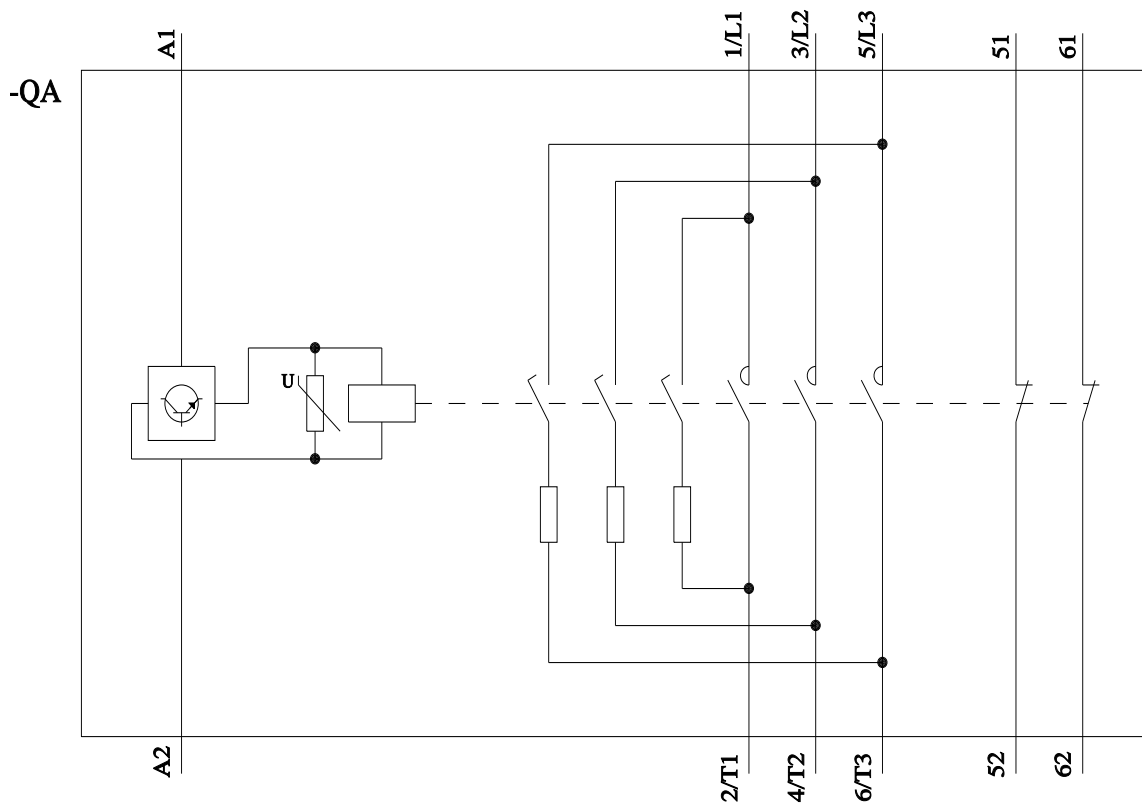
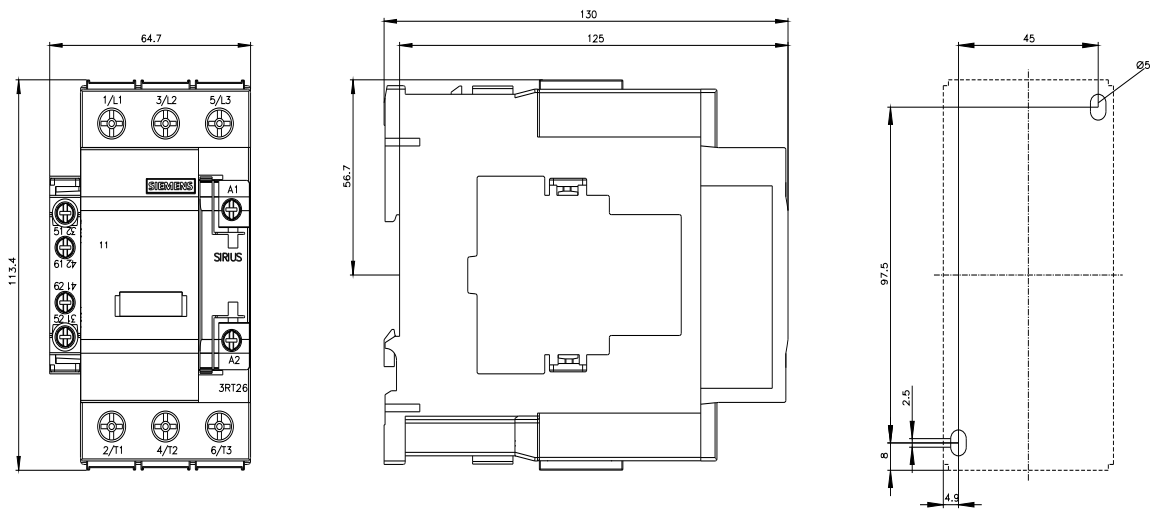

last modified:

11/11/2025

