



circuit breaker size S0 for system protection without phase failure protection A-release 0.9...1.25 A short-circuit release 16 A screw terminal standard switching capacity

<b>product brand name</b>	SIRIUS
<b>product designation</b>	Circuit breaker
<b>design of the product</b>	for system protection
<b>product type designation</b>	3RV2
<b>General technical data</b>	
<b>size of the circuit-breaker</b>	S0
<b>size of contactor can be combined company-specific</b>	S00, S0
product extension auxiliary switch	Yes
<b>power loss [W] for rated value of the current</b>	
• at AC in hot operating state	7.25 W
• at AC in hot operating state per pole	2.4 W
insulation voltage with degree of pollution 3 at AC rated value	690 V
<b>surge voltage resistance rated value</b>	6 kV
<b>shock resistance according to IEC 60068-2-27</b>	25g / 11 ms Sinus
<b>mechanical service life (operating cycles)</b>	
• of the main contacts typical	100 000
• of auxiliary contacts typical	100 000
electrical endurance (operating cycles) typical	100 000
<b>reference code according to IEC 81346-2</b>	Q
<b>Substance Prohibition (Date)</b>	10/01/2009
<b>Weight</b>	0.35 kg
<b>Ambient conditions</b>	
installation altitude at height above sea level maximum	2 000 m
<b>ambient temperature</b>	
• during operation	-20 ... +60 °C
• during storage	-50 ... +80 °C
• during transport	-50 ... +80 °C
relative humidity during operation	10 ... 95 %
<b>Environmental footprint</b>	
Environmental Product Declaration (EPD)	Yes
global warming potential [CO2 eq] total	75.078 kg
global warming potential [CO2 eq] during manufacturing	2.68 kg
global warming potential [CO2 eq] during sales	0.143 kg
global warming potential [CO2 eq] during operation	72.7 kg
global warming potential [CO2 eq] after end of life	-0.445 kg
<b>Main circuit</b>	
<b>number of poles for main current circuit</b>	3
<b>adjustable current response value current of the current-dependent overload release</b>	0.9 ... 1.25 A
<b>type of voltage for main current circuit</b>	AC

<b>operating voltage</b>	
<ul style="list-style-type: none"> <li>● rated value</li> <li>● at AC-3 rated value maximum</li> <li>● at AC-3e rated value maximum</li> </ul>	20 ... 690 V 690 V 690 V
<b>operating frequency rated value</b>	50 ... 60 Hz
<b>operational current rated value</b>	1.25 A
<b>operational current</b>	
<ul style="list-style-type: none"> <li>● at AC-3 at 400 V rated value</li> <li>● at AC-3e at 400 V rated value</li> </ul>	1.25 A 1.25 A
<b>operating power</b>	
<ul style="list-style-type: none"> <li>● at AC-3               <ul style="list-style-type: none"> <li>— at 230 V rated value</li> <li>— at 400 V rated value</li> <li>— at 500 V rated value</li> <li>— at 690 V rated value</li> </ul> </li> <li>● at AC-3e               <ul style="list-style-type: none"> <li>— at 230 V rated value</li> <li>— at 400 V rated value</li> <li>— at 500 V rated value</li> <li>— at 690 V rated value</li> </ul> </li> </ul>	0.2 kW 0.4 kW 0.4 kW 0.8 kW  0.2 kW 0.4 kW 0.4 kW 0.8 kW
<b>operating frequency</b>	
<ul style="list-style-type: none"> <li>● at AC-3 maximum</li> <li>● at AC-3e maximum</li> </ul>	15 1/h 15 1/h
<b>Auxiliary circuit</b>	
<b>type of voltage for auxiliary and control circuit</b>	AC/DC
<b>number of NC contacts for auxiliary contacts</b>	0
<b>number of NO contacts for auxiliary contacts</b>	0
number of CO contacts for auxiliary contacts	0
<b>Protective and monitoring functions</b>	
<b>product function</b>	
<ul style="list-style-type: none"> <li>● ground fault detection</li> <li>● phase failure detection</li> </ul>	No No
<b>trip class</b>	CLASS 10
<b>design of the overload release</b>	thermal
<b>maximum short-circuit current breaking capacity (Icu)</b>	
<ul style="list-style-type: none"> <li>● at AC at 240 V rated value</li> <li>● at AC at 400 V rated value</li> <li>● at AC at 500 V rated value</li> <li>● at AC at 690 V rated value</li> </ul>	100 kA 100 kA 100 kA 100 kA
<b>operating short-circuit current breaking capacity (Ics) at AC</b>	
<ul style="list-style-type: none"> <li>● at 240 V rated value</li> <li>● at 400 V rated value</li> <li>● at 500 V rated value</li> <li>● at 690 V rated value</li> </ul>	100 kA 100 kA 100 kA 100 kA
response value current of instantaneous short-circuit trip unit	16 A
<b>Short-circuit protection</b>	
<b>product function short circuit protection</b>	Yes
<b>design of the short-circuit trip</b>	magnetic
<b>design of the fuse link for IT network for short-circuit protection of the main circuit</b>	
<ul style="list-style-type: none"> <li>● at 500 V</li> <li>● at 690 V</li> </ul>	gG 16 A gG 16 A
<b>Installation/ mounting/ dimensions</b>	
<b>mounting position</b>	any
<b>fastening method</b>	screw and snap-on mounting onto 35 mm DIN rail according to DIN EN 60715
<b>height</b>	97 mm
<b>width</b>	45 mm
<b>depth</b>	97 mm
<b>required spacing</b>	
<ul style="list-style-type: none"> <li>● with side-by-side mounting at the side</li> <li>● for grounded parts at 400 V</li> </ul>	0 mm

— downwards	30 mm
— upwards	30 mm
— at the side	9 mm
• for live parts at 400 V	
— downwards	30 mm
— upwards	30 mm
— at the side	9 mm
• for grounded parts at 500 V	
— downwards	30 mm
— upwards	30 mm
— at the side	9 mm
• for live parts at 500 V	
— downwards	30 mm
— upwards	30 mm
— at the side	9 mm
• for grounded parts at 690 V	
— downwards	50 mm
— upwards	50 mm
— backwards	0 mm
— at the side	30 mm
— forwards	0 mm
• for live parts at 690 V	
— downwards	50 mm
— upwards	50 mm
— backwards	0 mm
— at the side	30 mm
— forwards	0 mm

#### Connections/ Terminals

<b>type of electrical connection</b>	
• for main current circuit	screw-type terminals
<b>arrangement of electrical connectors for main current circuit</b>	Top and bottom
<b>type of connectable conductor cross-sections</b>	
• for main contacts	
— solid or stranded	2x (1 ... 2.5 mm <sup>2</sup> ), 2x (2.5 ... 10 mm <sup>2</sup> )
— finely stranded with core end processing	2x (1 ... 2.5 mm <sup>2</sup> ), 2x (2.5 ... 6 mm <sup>2</sup> ), 1x 10 mm <sup>2</sup>
<b>tightening torque</b>	
• for main contacts with screw-type terminals	2 ... 2.5 N·m
<b>design of screwdriver shaft</b>	Diameter 5 to 6 mm
<b>size of the screwdriver tip</b>	Pozidriv size 2
<b>design of the thread of the connection screw</b>	
• for main contacts	M4

#### Safety related data

product function suitable for safety function	Yes
<b>suitability for use</b>	
• safety-related switching on	No
• safety-related switching OFF	Yes
<b>service life maximum</b>	10 a
<b>test wear-related service life necessary</b>	Yes
<b>proportion of dangerous failures</b>	
• with low demand rate according to SN 31920	40 %
• with high demand rate according to SN 31920	50 %
<b>B10 value with high demand rate according to SN 31920</b>	5 000
<b>failure rate [FIT] with low demand rate according to SN 31920</b>	50 FIT
ISO 13849	
<b>device type according to ISO 13849-1</b>	3
<b>overdimensioning according to ISO 13849-2 necessary</b>	Yes
IEC 61508	
<b>safety device type according to IEC 61508-2</b>	Type A
<b>T1 value</b>	

• for proof test interval or service life according to IEC 61508

10 a

#### Electrical Safety

protection class IP on the front according to IEC 60529

IP20

touch protection on the front according to IEC 60529

finger-safe, for vertical contact from the front

#### Display

display version for switching status

Handle

#### Approvals Certificates

##### General Product Approval



##### Test Certificates

##### Maritime application

[Type Test Certificates/Test Report](#)

[Special Test Certificate](#)



##### Maritime application

##### other



[Confirmation](#)

[Miscellaneous](#)



##### Railway

##### Environment

[Special Test Certificate](#)

[Confirmation](#)



Siemens EcoTech



[Environmental Confirmations](#)

#### Further information

##### Information on the packaging

<https://support.industry.siemens.com/cs/ww/en/view/109813875>

##### Information for data generation and storage

<https://support.industry.siemens.com/cs/ww/en/view/109995012>

Information- and Downloadcenter (Catalogs, Brochures,...)

<https://www.siemens.com/ic10>

##### Industry Mall (Online ordering system)

<https://mall.industry.siemens.com/mall/en/en/Catalog/product?mlfb=3RV2021-0KA10-0DA0>

##### Cax online generator

<https://support.automation.siemens.com/WW/CAXorder/default.aspx?lang=en&mlfb=3RV2021-0KA10-0DA0>

##### Service&Support (Manuals, Certificates, Characteristics, FAQs,...)

<https://support.industry.siemens.com/cs/ww/en/ps/3RV2021-0KA10-0DA0>

Image database (product images, 2D dimension drawings, 3D models, device circuit diagrams, EPLAN macros, ...)

[https://www.automation.siemens.com/bilddb/cax\\_de.aspx?mlfb=3RV2021-0KA10-0DA0&lang=en](https://www.automation.siemens.com/bilddb/cax_de.aspx?mlfb=3RV2021-0KA10-0DA0&lang=en)

##### Characteristic: Tripping characteristics, I<sup>2</sup>t, Let-through current

<https://support.industry.siemens.com/cs/ww/en/ps/3RV2021-0KA10-0DA0/char>

##### Further characteristics (e.g. electrical endurance, switching frequency)

<https://www.automation.siemens.com/bilddb/index.aspx?view=Search&mlfb=3RV2021-0KA10-0DA0&objecttype=14&gridview=view1>

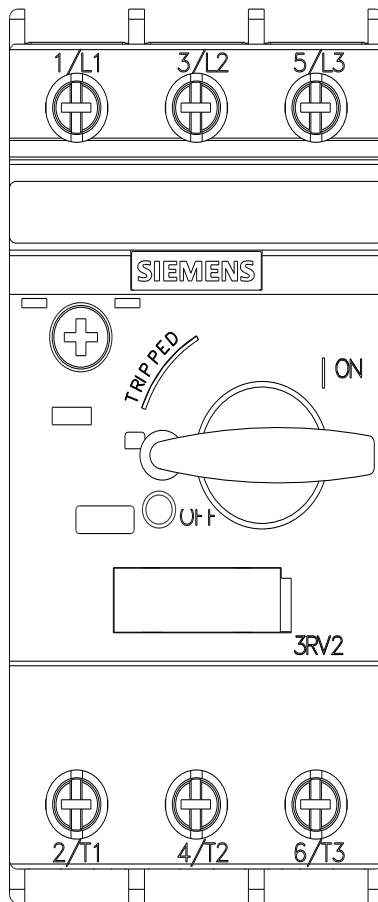



last modified:

11/11/2025 