

Siemens
EcoTech



Circuit breaker size S0 for motor protection, CLASS 10 with overload relay function
A-release 18...25 A N-release 325 A Screw terminal Standard switching capacity



product brand name	SIRIUS
product designation	Circuit breaker
design of the product	For motor protection with overload relay function
product type designation	3RV2
General technical data	
size of the circuit-breaker	S0
size of contactor can be combined company-specific	S00, S0
product extension auxiliary switch	Yes
power loss [W] for rated value of the current	
• at AC in hot operating state	10.5 W
• at AC in hot operating state per pole	3.5 W
insulation voltage with degree of pollution 3 at AC rated value	690 V
surge voltage resistance rated value	6 kV
shock resistance according to IEC 60068-2-27	25g / 11 ms
mechanical service life (operating cycles)	
• of the main contacts typical	100 000
• of auxiliary contacts typical	100 000
electrical endurance (operating cycles) typical	100 000
reference code according to IEC 81346-2	Q
Substance Prohibitance (Date)	10/01/2009
SVHC substance name	Lead - 7439-92-1 Lead titanium zirconium oxide - 12626-81-2
Weight	431 g
Ambient conditions	
installation altitude at height above sea level maximum	2 000 m
ambient temperature	
• during operation	-20 ... +60 °C
• during storage	-50 ... +80 °C
• during transport	-50 ... +80 °C
relative humidity during operation	10 ... 95 %
Environmental footprint	
Environmental Product Declaration(EPD)	Yes
global warming potential [CO2 eq] total	75.078 kg
global warming potential [CO2 eq] during manufacturing	2.68 kg
global warming potential [CO2 eq] during sales	0.143 kg
global warming potential [CO2 eq] during operation	72.7 kg
global warming potential [CO2 eq] after end of life	-0.445 kg

Siemens Eco Profile (SEP)	Siemens EcoTech
Main circuit	
number of poles for main current circuit	3
adjustable current response value current of the current-dependent overload release	18 ... 25 A
type of voltage for main current circuit	AC
operating voltage	
• rated value	20 ... 690 V
• at AC-3 rated value maximum	690 V
• at AC-3e rated value maximum	690 V
operating frequency rated value	50 ... 60 Hz
operational current rated value	25 A
operational current	
• at AC-3 at 400 V rated value	25 A
• at AC-3e at 400 V rated value	25 A
operating power	
• at AC-3	
— at 230 V rated value	5.5 kW
— at 400 V rated value	11 kW
— at 500 V rated value	15 kW
— at 690 V rated value	22 kW
• at AC-3e	
— at 230 V rated value	5.5 kW
— at 400 V rated value	11 kW
— at 500 V rated value	15 kW
— at 690 V rated value	22 kW
operating frequency	
• at AC-3 maximum	15 1/h
• at AC-3e maximum	15 1/h
Auxiliary circuit	
design of the auxiliary switch	laterally
type of voltage for auxiliary and control circuit	AC/DC
number of NC contacts for auxiliary contacts	0
number of NO contacts for auxiliary contacts	0
number of CO contacts for auxiliary contacts	0
operational current of auxiliary contacts at AC-15	
• at 24 V	1.5 A
• at 230 V	1.5 A
operational current of auxiliary contacts at DC-13	
• at 24 V	1 A
Protective and monitoring functions	
product function	
• ground fault detection	No
• phase failure detection	Yes
trip class	CLASS 10
design of the overload release	thermal
maximum short-circuit current breaking capacity (Icu)	
• at AC at 240 V rated value	100 kA
• at AC at 400 V rated value	55 kA
• at AC at 500 V rated value	10 kA
• at AC at 690 V rated value	4 kA
operating short-circuit current breaking capacity (Ics) at AC	
• at 240 V rated value	100 kA
• at 400 V rated value	25 kA
• at 500 V rated value	5 kA
• at 690 V rated value	2 kA
response value current of instantaneous short-circuit trip unit	325 A
UL/CSA ratings	
full-load current (FLA) for 3-phase AC motor	
• at 480 V rated value	25 A
• at 600 V rated value	25 A

yielded mechanical performance [hp]	
<ul style="list-style-type: none"> ● for single-phase AC motor <ul style="list-style-type: none"> — at 110/120 V rated value — at 230 V rated value ● for 3-phase AC motor <ul style="list-style-type: none"> — at 200/208 V rated value — at 220/230 V rated value — at 460/480 V rated value 	<p>2 hp</p> <p>3 hp</p> <p>5 hp</p> <p>7.5 hp</p> <p>15 hp</p>
contact rating of auxiliary contacts according to UL	C600 / R300
Short-circuit protection	
product function short circuit protection	Yes
design of the short-circuit trip	magnetic
design of the fuse link	
<ul style="list-style-type: none"> ● for short-circuit protection of the auxiliary switch required 	fuse gL/gG: 6 A, quick: 10 A
design of the fuse link for IT network for short-circuit protection of the main circuit	
<ul style="list-style-type: none"> ● at 400 V ● at 500 V ● at 690 V 	<p>gL/gG 63 A</p> <p>gL/gG 50 A</p> <p>gL/gG 50 A</p>
Installation/ mounting/ dimensions	
mounting position	any
fastening method	screw and snap-on mounting onto 35 mm DIN rail according to DIN EN 60715
height	97 mm
width	65 mm
depth	97 mm
required spacing	
<ul style="list-style-type: none"> ● with side-by-side mounting at the side ● for grounded parts at 400 V <ul style="list-style-type: none"> — downwards — upwards — at the side ● for live parts at 400 V <ul style="list-style-type: none"> — downwards — upwards — at the side ● for grounded parts at 500 V <ul style="list-style-type: none"> — downwards — upwards — at the side ● for live parts at 500 V <ul style="list-style-type: none"> — downwards — upwards — at the side ● for grounded parts at 690 V <ul style="list-style-type: none"> — downwards — upwards — backwards — at the side — forwards ● for live parts at 690 V <ul style="list-style-type: none"> — downwards — upwards — backwards — at the side — forwards 	<p>0 mm</p> <p>30 mm</p> <p>30 mm</p> <p>9 mm</p> <p>30 mm</p> <p>30 mm</p> <p>9 mm</p> <p>30 mm</p> <p>30 mm</p> <p>9 mm</p> <p>30 mm</p> <p>30 mm</p> <p>9 mm</p> <p>50 mm</p> <p>50 mm</p> <p>0 mm</p> <p>30 mm</p> <p>0 mm</p> <p>50 mm</p> <p>50 mm</p> <p>0 mm</p> <p>30 mm</p> <p>0 mm</p>
Connections/ Terminals	
type of electrical connection	
<ul style="list-style-type: none"> ● for main current circuit ● for auxiliary and control circuit 	<p>screw-type terminals</p> <p>screw-type terminals</p>
arrangement of electrical connectors for main current circuit	Top and bottom

type of connectable conductor cross-sections	
<ul style="list-style-type: none"> for main contacts <ul style="list-style-type: none"> — solid or stranded — finely stranded with core end processing for AWG cables for main contacts 	<p>2x (1 ... 2.5 mm²), 2x (2.5 ... 10 mm²)</p> <p>2x (1 ... 2.5 mm²), 2x (2.5 ... 6 mm²), 1x 10 mm²</p> <p>2x (16 ... 12), 2x (14 ... 8)</p>
type of connectable conductor cross-sections	
<ul style="list-style-type: none"> for auxiliary contacts <ul style="list-style-type: none"> — solid or stranded — finely stranded with core end processing for AWG cables for auxiliary contacts 	<p>2x (0.5 ... 1.5 mm²), 2x (0.75 ... 2.5 mm²)</p> <p>2x (0.5 ... 1.5 mm²), 2x (0.75 ... 2.5 mm²)</p> <p>2x (20 ... 16), 2x (18 ... 14)</p>
tightening torque	
<ul style="list-style-type: none"> for main contacts with screw-type terminals for auxiliary contacts with screw-type terminals 	<p>2 ... 2.5 N·m</p> <p>0.8 ... 1.2 N·m</p>
design of screwdriver shaft	Diameter 5 to 6 mm
size of the screwdriver tip	Pozidriv size 2
design of the thread of the connection screw	
<ul style="list-style-type: none"> for main contacts of the auxiliary and control contacts 	<p>M4</p> <p>M3</p>

Safety related data

product function suitable for safety function	Yes
suitability for use	
<ul style="list-style-type: none"> safety-related switching on safety-related switching OFF 	<p>No</p> <p>Yes</p>
service life maximum	10 a
test wear-related service life necessary	Yes
proportion of dangerous failures	
<ul style="list-style-type: none"> with low demand rate according to SN 31920 with high demand rate according to SN 31920 	<p>40 %</p> <p>50 %</p>
B10 value with high demand rate according to SN 31920	5 000
failure rate [FIT] with low demand rate according to SN 31920	50 FIT
ISO 13849	
device type according to ISO 13849-1	3
overdimensioning according to ISO 13849-2 necessary	Yes
IEC 61508	
safety device type according to IEC 61508-2	Type A
T1 value	
<ul style="list-style-type: none"> for proof test interval or service life according to IEC 61508 	10 a

Electrical Safety	
protection class IP on the front according to IEC 60529	IP20
touch protection on the front according to IEC 60529	finger-safe, for vertical contact from the front

Display

display version for switching status	Handle
--------------------------------------	--------

Approvals Certificates

General Product Approval



[KC](#)



General Product Approval	Test Certificates	Maritime application
--------------------------	-------------------	----------------------



[Special Test Certificate](#)

[Type Test Certificates/Test Report](#)



Maritime application	other
----------------------	-------



Miscellaneous



other

[Confirmation](#)



Railway

[Special Test Certificate](#)

[Confirmation](#)

Environment



Siemens EcoTech



Environment

[Environmental Confirmations](#)

Further information

Information on the packaging

<https://support.industry.siemens.com/cs/ww/en/view/109813875>

Information for data generation and storage

<https://support.industry.siemens.com/cs/ww/en/view/109995012>

Information- and Downloadcenter (Catalogs, Brochures,...)

<https://www.siemens.com/ic10>

Industry Mall (Online ordering system)

<https://mall.industry.siemens.com/mall/en/en/Catalog/product?mlfb=3RV2121-4DA10>

Cax online generator

<https://support.automation.siemens.com/WW/CAXorder/default.aspx?lang=en&mlfb=3RV2121-4DA10>

Service&Support (Manuals, Certificates, Characteristics, FAQs,...)

<https://support.industry.siemens.com/cs/ww/en/ps/3RV2121-4DA10>

Image database (product images, 2D dimension drawings, 3D models, device circuit diagrams, EPLAN macros, ...)

https://www.automation.siemens.com/bilddb/cax_de.aspx?mlfb=3RV2121-4DA10&lang=en

Characteristic: Tripping characteristics, I²t, Let-through current

<https://support.industry.siemens.com/cs/ww/en/ps/3RV2121-4DA10/char>

Further characteristics (e.g. electrical endurance, switching frequency)

<https://www.automation.siemens.com/bilddb/index.aspx?view=Search&mlfb=3RV2121-4DA10&objecttype=14&gridview=view1>

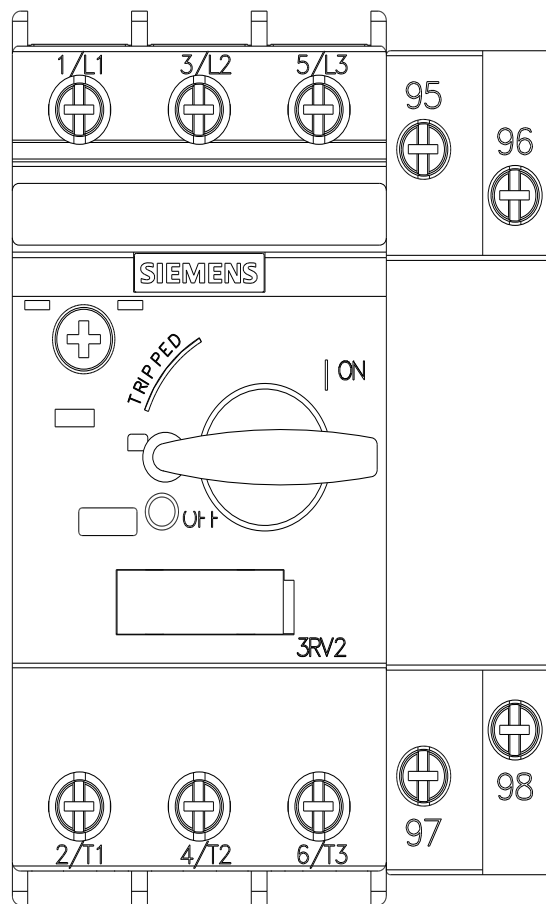
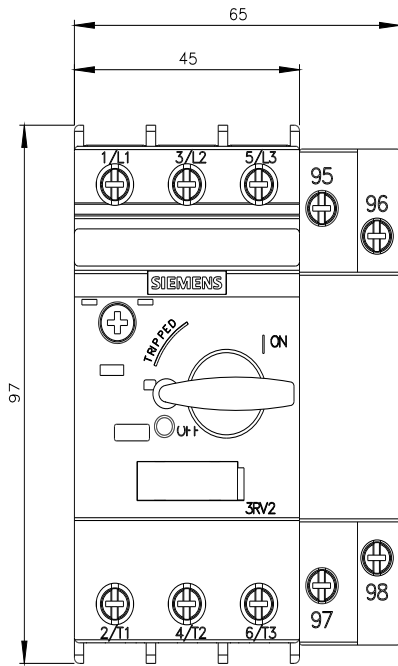

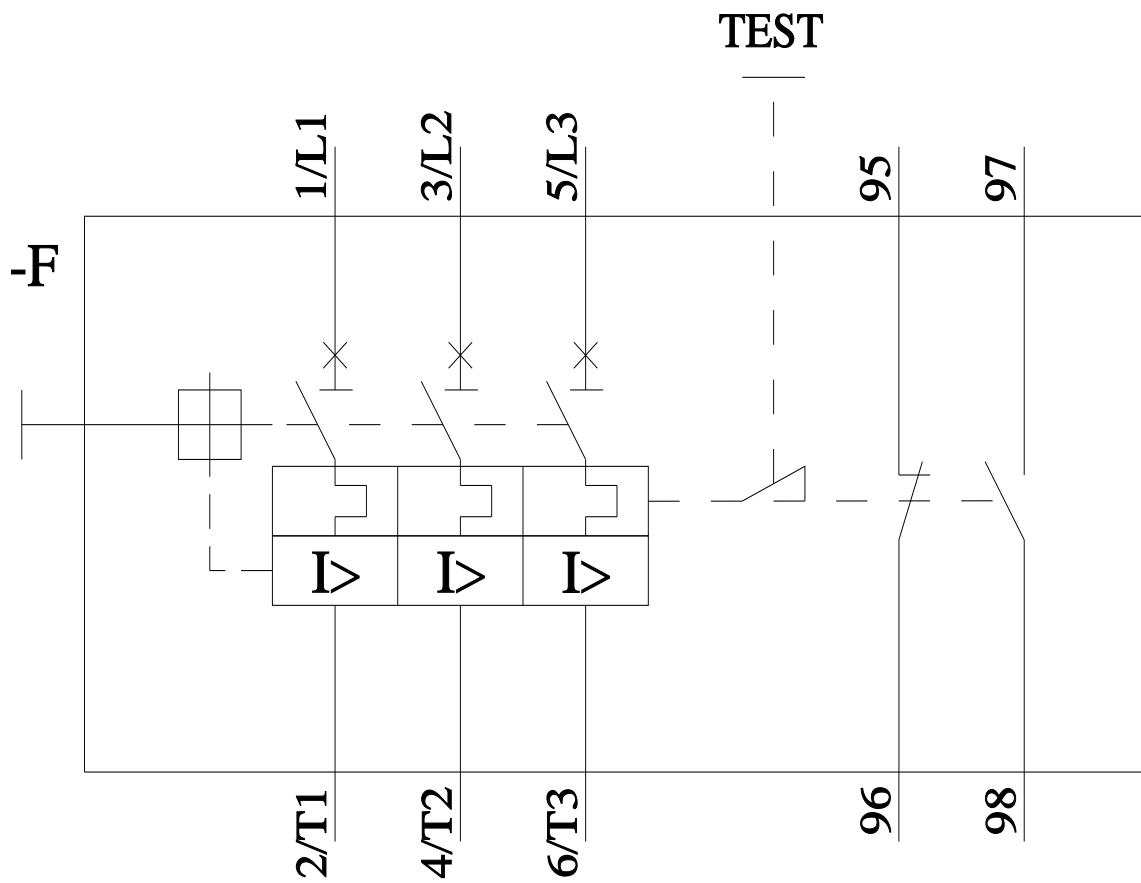

last modified:

11/11/2025 