



SIRIUS safety relay Basic unit Advanced series with time delay 5-300 s Relay enabling circuits 2 NO instantaneous 2 NO delayed $U_s = 24$ V DC screw terminal

product brand name	SIRIUS
product category	Safety relays
product designation	safety relays
design of the product	Relay enabling circuits
product type designation	3SK1
product line	Advanced basic unit
Product Function	
product function parameterizable	sensor floating / sensor non-floating, monitored start-up / automatic start, 1-channel / 2-channel sensor connection, cross-circuit detection, startup testing, antivalent sensors, 2-hand switches, time delay
product function	
<ul style="list-style-type: none"> • automatic start • light barrier monitoring • protective door monitoring • magnetically operated switch monitoring NC-NO • magnetically operated switch monitoring NC-NC • laser scanner monitoring • light array monitoring • EMERGENCY OFF function • monitored start-up • pressure-sensitive mat monitoring 	<ul style="list-style-type: none"> Yes Yes Yes Yes Yes Yes Yes Yes Yes No
suitability for interaction press control	Yes
suitability for operation device connector 3ZY12	Yes
suitability for use	
<ul style="list-style-type: none"> • monitoring of floating sensors • monitoring of non-floating sensors • position switch monitoring • EMERGENCY-OFF circuit monitoring • opto-electronic protection device monitoring • magnetically operated switch monitoring • safety switch • safety-related circuits 	<ul style="list-style-type: none"> Yes Yes Yes Yes Yes Yes Yes Yes
General technical data	
certificate of suitability UL approval	Yes
product feature cross-circuit-proof	Yes
power loss [W] maximum	2.5 W
insulation voltage rated value	300 V
degree of pollution	3
overvoltage category	3
surge voltage resistance rated value	4 000 V

protection class IP of the enclosure	IP20
shock resistance	10g / 11 ms
vibration resistance according to IEC 60068-2-6	5 ... 500 Hz: 0.75 mm
operating frequency maximum	360 1/h
mechanical service life (operating cycles) typical	10 000 000
thermal current of the switching element with contacts maximum	5 A
reference code according to IEC 81346-2	F
Substance Prohibitance (Date)	11/05/2012
SVHC substance name	Lead - 7439-92-1 Lead monoxide (lead oxide) - 1317-36-8 2,2',6,6'-tetrabromo-4,4'-isopropylidenediphenol - 79-94-7 Lead titanium zirconium oxide - 12626-81-2 6,6'-di-tert-butyl-2,2'-methylenedi-p-cresol - 119-47-1 4,4'-isopropylidenediphenol (Bisphenol A, BPA) - 80-05-7
Weight	0.284 kg
Ambient conditions	
installation altitude at height above sea level maximum	4 000 m; Derating, see Product Notification 109792701
ambient temperature	
• during operation	-25 ... +60 °C
• during storage	-40 ... +80 °C
relative humidity during operation	10 ... 95 %
air pressure according to SN 31205	900 ... 1 060 hPa
Electromagnetic compatibility	
installation environment regarding EMC	This product is suitable for Class A environments only. In household environments, this device can cause unwanted radio interference. The user is required to implement appropriate measures in this case.
EMC emitted interference	IEC 60947-5-1, Class A
Safety related data	
product function suitable for safety function	Yes
safe state	Safety outputs switched off
test wear-related service life necessary	Yes
function test interval maximum	1 a
diagnostics test interval by internal test function maximum	600 s
stop category according to IEC 60204-1	0 / 1
IEC 62061	
SIL Claim Limit (subsystem) according to EN 62061	3
Safety Integrity Level (SIL)	
• according to IEC 62061	SIL 3
• at single-channel evaluation according to IEC 62061	1
• at 2-channel evaluation according to IEC 62061	3
PFHD with high demand rate according to IEC 62061	3.7E-9 1/h
ISO 13849	
category according to EN ISO 13849-1	4
performance level (PL)	
• according to ISO 13849-1	PL e
• at single-channel evaluation according to ISO 13849-1	c
• at 2-channel evaluation according to ISO 13849-1	e
• for delayed release circuit according to ISO 13849-1	e
category	
• according to ISO 13849-1	4
• at 2-channel evaluation according to ISO 13849-1	4
overdimensioning according to ISO 13849-2 necessary	No
IEC 61508	
Safety Integrity Level (SIL)	
• according to IEC 61508	3
• for delayed release circuit according to IEC 61508	SIL3
• at single-channel evaluation according to IEC 61508	1
• at 2-channel evaluation according to IEC 61508	3
safety device type according to IEC 61508-2	Type B
PFHD with high demand rate according to IEC 61508	3.7E-9 1/h

Average probability of failure on demand (PFDavg) with low demand rate acc. to IEC 61508	7E-6 1/y
PFDavg with low demand rate according to IEC 61508	7E-6
Safe failure fraction (SFF)	99 %
hardware fault tolerance	
• according to IEC 61508	1
• at single-channel evaluation according to IEC 61508	0
• at 2-channel evaluation according to IEC 61508	1
T1 value	
• of service life according to IEC 61508	20 a
• for proof test interval or service life according to IEC 61508	20 a
Electrical Safety	
touch protection against electrical shock	finger-safe
Short-circuit protection	
design of the fuse link	
• for short-circuit protection of the NO contacts of the relay outputs required	gL/gG: 6A or circuit breaker type A: 3A or circuit breaker type B: 2A or circuit breaker type C: 1A
Inputs	
design of input	
• cascading input/functional switching	Yes
• feedback input	Yes
• start input	Yes
pulse duration of the sensor input minimum	75 ms
number of sensor inputs 1-channel or 2-channel	1
Outputs	
number of outputs as contact-affected switching element	
• as NC contact	
— for signaling function instantaneous contact	0
• as NO contact	
— safety-related instantaneous contact	2
— safety-related delayed switching	2
switching capacity current of the NO contacts of the relay outputs at DC-13	
• at 24 V	3 A
• at 115 V	0.2 A
• at 230 V	0.1 A
switching capacity current of the NO contacts of the relay outputs at AC-15	
• at 115 V	3 A
• at 230 V	3 A
total current maximum	12 A
operational current at 17 V minimum	5 mA
Times	
make time with automatic start	
• at DC maximum	110 ms
make time with automatic start after power failure	
• typical	6 500 ms
• maximum	6 500 ms
make time with monitored start	
• maximum	110 ms
backslide delay time after opening of the safety circuits typical	40 ms
backslide delay time in the event of power failure	
• typical	30 ms
• maximum	40 ms
adjustable OFF-delay time after opening of the safety circuits	5 ... 300 s
recovery time after opening of the safety circuits typical	30 ms
recovery time after power failure typical	6.5 s
pulse duration	

• of the ON pushbutton input minimum	0.15 s
Control circuit/ Control	
type of voltage of the control supply voltage	DC
control supply voltage at DC rated value	24 V
operating range factor control supply voltage rated value of magnet coil at DC	
• initial value	0.8
• full-scale value	1.2
Installation/ mounting/ dimensions	
mounting position	any
fastening method	screw and snap-on mounting
height	100 mm
width	22.5 mm
depth	121.6 mm
required spacing	
• for grounded parts at the side	5 mm
Connections/ Terminals	
type of electrical connection	screw terminal
wire length	
• with Cu 1.5 mm ² and 150 nF/km per sensor circuit maximum	4 000 m
type of connectable conductor cross-sections	
• solid	1x (0.5 ... 2.5 mm ²), 2x (1.0 ... 1.5 mm ²)
• finely stranded with core end processing	1x (0.5 ... 2.5 mm ²), 2x (0.5 ... 1.0 mm ²)
• for AWG cables solid	1x (20 ... 14), 2x (18 ... 16)
• for AWG cables stranded	1x (20 ... 16), 2x (20 ... 16)
type of electrical connection plug-in socket	No

Approvals Certificates		
General Product Approval	EMV	Functional Safety



[Type Examination Certificate](#)

Test Certificates	Maritime application	other	Environment
-------------------	----------------------	-------	-------------

[Type Test Certificates/Test Report](#)



[Confirmation](#)

[Environmental Confirmations](#)

Further information

Information on the packaging

<https://support.industry.siemens.com/cs/ww/en/view/109813875>

Information for data generation and storage

<https://support.industry.siemens.com/cs/ww/en/view/109995012>

Information- and Downloadcenter (Catalogs, Brochures,...)

<https://www.siemens.com/ic10>

Industry Mall (Online ordering system)

<https://mall.industry.siemens.com/mall/en/en/Catalog/product?mlfb=3SK1121-1CB44>

Cax online generator

<https://support.automation.siemens.com/WW/CAXorder/default.aspx?lang=en&mlfb=3SK1121-1CB44>

Service&Support (Manuals, Certificates, Characteristics, FAQs,...)

<https://support.industry.siemens.com/cs/ww/en/ps/3SK1121-1CB44>

Image database (product images, 2D dimension drawings, 3D models, device circuit diagrams, EPLAN macros, ...)

https://www.automation.siemens.com/bilddb/cax_de.aspx?mlfb=3SK1121-1CB44&lang=en

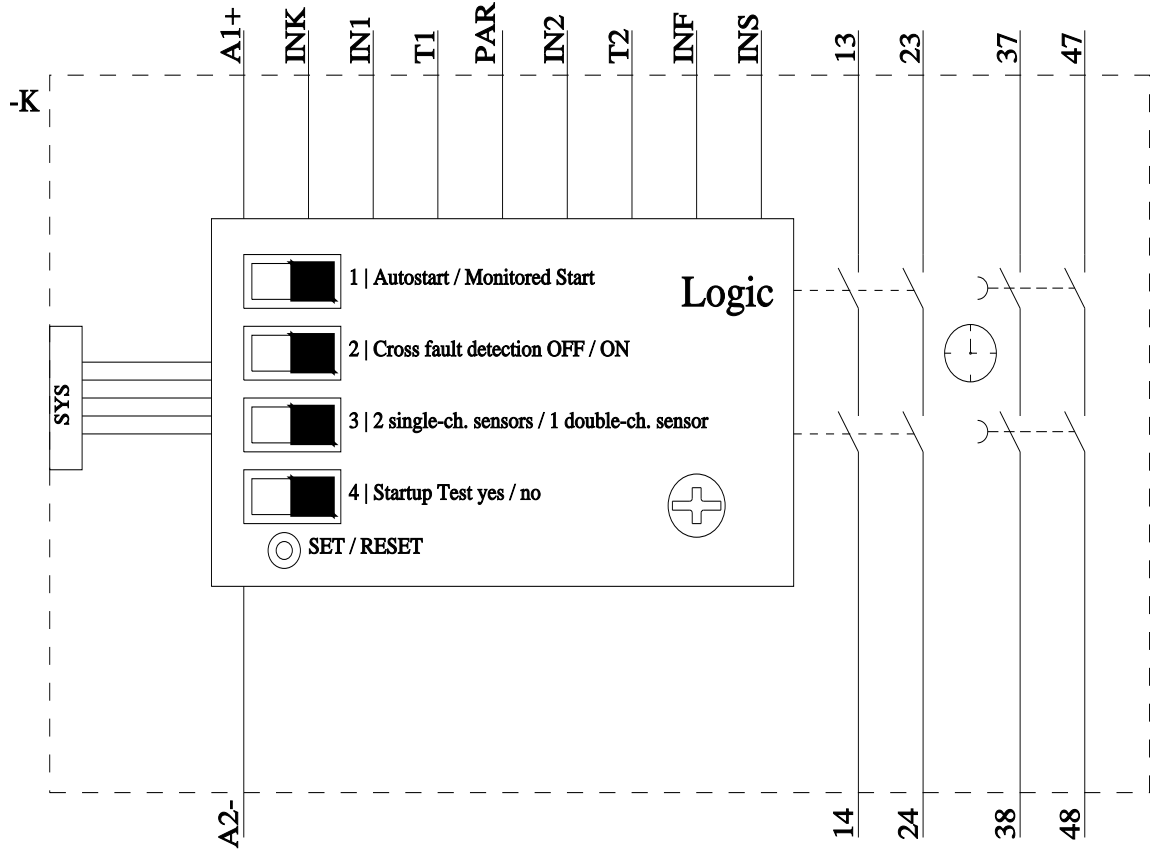
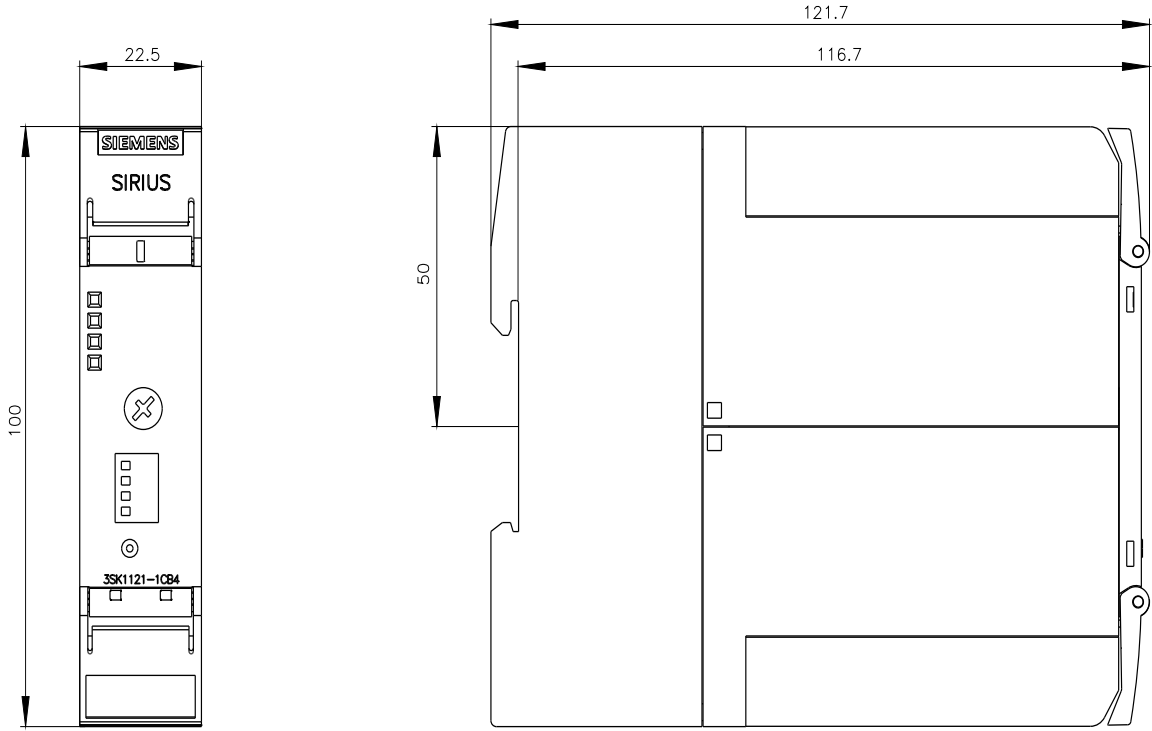

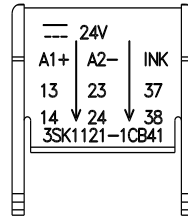
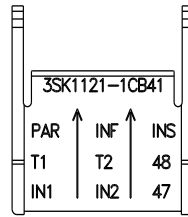
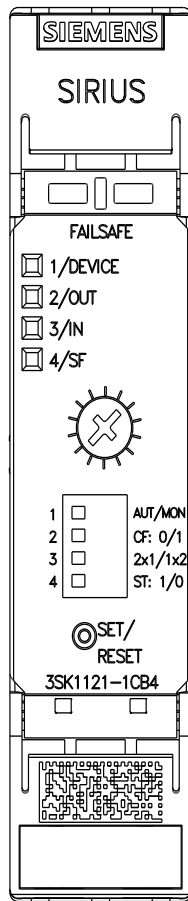

last modified:

10/17/2025