



SIRIUS safety relay Basic unit Advanced series with time delay 0.05-3 s electronic enabling circuits 2 NO instantaneous 2 NO delayed $U_s = 24\text{ V DC}$ Spring-type terminal (push-in)

product brand name	SIRIUS
product category	Safety relays
product designation	safety relays
design of the product	Solid-state enabling circuits
product type designation	3SK1
product line	Advanced basic unit
Product Function	
product function parameterizable	sensor floating / sensor non-floating, monitored start-up / automatic start, 1-channel / 2-channel sensor connection, cross-circuit detection, startup testing, antivalent sensors, 2-hand switches, time delay
product function	
<ul style="list-style-type: none"> • automatic start • light barrier monitoring • protective door monitoring • magnetically operated switch monitoring NC-NO • magnetically operated switch monitoring NC-NC • laser scanner monitoring • light array monitoring • EMERGENCY OFF function • monitored start-up • pressure-sensitive mat monitoring 	<ul style="list-style-type: none"> Yes Yes Yes Yes Yes Yes Yes Yes Yes No
suitability for interaction press control	Yes
suitability for operation device connector 3ZY12	Yes
suitability for use	
<ul style="list-style-type: none"> • monitoring of floating sensors • monitoring of non-floating sensors • position switch monitoring • EMERGENCY-OFF circuit monitoring • opto-electronic protection device monitoring • magnetically operated switch monitoring • safety switch • safety-related circuits 	<ul style="list-style-type: none"> Yes Yes Yes Yes Yes Yes Yes Yes
General technical data	
certificate of suitability UL approval	Yes
product feature cross-circuit-proof	Yes
power loss [W] maximum	2 W
insulation voltage rated value	50 V
degree of pollution	3
overvoltage category	3
surge voltage resistance rated value	800 V
protection class IP of the enclosure	IP20

shock resistance	10g / 11 ms
vibration resistance according to IEC 60068-2-6	5 ... 500 Hz: 0.75 mm
operating frequency maximum	2 000 1/h
reference code according to IEC 81346-2	F
Substance Prohibitance (Date)	11/05/2012
SVHC substance name	Lead - 7439-92-1 Lead monoxide (lead oxide) - 1317-36-8 Silicic acid, lead salt - 11120-22-2 2,2',6,6'-tetrabromo-4,4'-isopropylidenediphenol - 79-94-7 Lead titanium zirconium oxide - 12626-81-2 6,6'-di-tert-butyl-2,2'-methylenedi-p-cresol - 119-47-1 2-methyl-1-(4-methylthiophenyl)-2-morpholinopropan-1-one - 71868-10-5
Weight	0.186 kg
Ambient conditions	
installation altitude at height above sea level maximum	4 000 m; Derating, see Product Notification 109792701
ambient temperature	
• during operation	-25 ... +60 °C
• during storage	-40 ... +80 °C
relative humidity during operation	10 ... 95 %
air pressure according to SN 31205	900 ... 1 060 hPa
Electromagnetic compatibility	
installation environment regarding EMC	This product is suitable for Class A environments only. In household environments, this device can cause unwanted radio interference. The user is required to implement appropriate measures in this case.
EMC emitted interference	IEC 60947-5-1, Class A
Safety related data	
product function suitable for safety function	Yes
safe state	Safety outputs switched off
test wear-related service life necessary	No
diagnostics test interval by internal test function maximum	600 s
stop category according to IEC 60204-1	0 / 1
IEC 62061	
SIL Claim Limit (subsystem) according to EN 62061	3
Safety Integrity Level (SIL)	
• according to IEC 62061	SIL 3
• at single-channel evaluation according to IEC 62061	1
• at 2-channel evaluation according to IEC 62061	3
PFHD with high demand rate according to IEC 62061	1.5E-9 1/h
ISO 13849	
category according to EN ISO 13849-1	4
performance level (PL)	
• according to ISO 13849-1	PL e
• at single-channel evaluation according to ISO 13849-1	c
• at 2-channel evaluation according to ISO 13849-1	e
• for delayed release circuit according to ISO 13849-1	e
category	
• according to ISO 13849-1	4
• at 2-channel evaluation according to ISO 13849-1	4
overdimensioning according to ISO 13849-2 necessary	No
IEC 61508	
Safety Integrity Level (SIL)	
• according to IEC 61508	3
• for delayed release circuit according to IEC 61508	SIL3
• at single-channel evaluation according to IEC 61508	1
• at 2-channel evaluation according to IEC 61508	3
safety device type according to IEC 61508-2	Type B
PFHD with high demand rate according to IEC 61508	1.5E-9 1/h
Average probability of failure on demand (PFDavg) with low demand rate acc. to IEC 61508	7E-6 1/y
PFDavg with low demand rate according to IEC 61508	7E-6
Safe failure fraction (SFF)	99 %
hardware fault tolerance	
• according to IEC 61508	1

<ul style="list-style-type: none"> • at single-channel evaluation according to IEC 61508 • at 2-channel evaluation according to IEC 61508 	0 1
T1 value	
<ul style="list-style-type: none"> • of service life according to IEC 61508 • for proof test interval or service life according to IEC 61508 	20 a 20 a
Electrical Safety	
touch protection against electrical shock	finger-safe
Short-circuit protection	
design of the fuse link	
<ul style="list-style-type: none"> • for short-circuit protection of the NO contacts of the relay outputs required 	not required
Inputs	
design of input	
<ul style="list-style-type: none"> • cascading input/functional switching • feedback input • start input 	Yes Yes Yes
pulse duration of the sensor input minimum	60 ms
number of sensor inputs 1-channel or 2-channel	1
Outputs	
number of outputs as contact-affected switching element	
<ul style="list-style-type: none"> • as NO contact <ul style="list-style-type: none"> — safety-related instantaneous contact — safety-related delayed switching 	0 0
number of outputs as contact-less semiconductor switching element	
<ul style="list-style-type: none"> • for signaling function <ul style="list-style-type: none"> — instantaneous contact • safety-related <ul style="list-style-type: none"> — delayed switching — instantaneous contact 	0 2 2
switching capacity current of semiconductor outputs at DC-13 at 24 V	2 A
Times	
make time with automatic start	
<ul style="list-style-type: none"> • at DC maximum 	85 ms
make time with automatic start after power failure	
<ul style="list-style-type: none"> • typical • maximum 	6 500 ms 6 500 ms
make time with monitored start	
<ul style="list-style-type: none"> • maximum 	85 ms
backslide delay time after opening of the safety circuits typical	40 ms
adjustable OFF-delay time after opening of the safety circuits	0.05 ... 3 s
recovery time after opening of the safety circuits typical	30 ms
recovery time after power failure typical	6.5 s
pulse duration	
<ul style="list-style-type: none"> • of the ON pushbutton input minimum 	0.15 s
Control circuit/ Control	
type of voltage of the control supply voltage	DC
control supply voltage at DC rated value	24 V
operating range factor control supply voltage rated value of magnet coil at DC	
<ul style="list-style-type: none"> • initial value • full-scale value 	0.8 1.2
Installation/ mounting/ dimensions	
mounting position	any
fastening method	screw and snap-on mounting
height	100 mm
width	22.5 mm
depth	121.6 mm

required spacing	5 mm
<ul style="list-style-type: none"> for grounded parts at the side 	
Connections/ Terminals	
type of electrical connection	spring-loaded terminal (push-in)
wire length	4 000 m
<ul style="list-style-type: none"> with Cu 1.5 mm² and 150 nF/km per sensor circuit maximum 	
type of connectable conductor cross-sections	
<ul style="list-style-type: none"> solid finely stranded with core end processing finely stranded without core end processing for AWG cables solid for AWG cables stranded 	1x (0.5 ... 1.5 mm ²), 2x (0.5 ... 1.5 mm ²) 1x (0.5 ... 1.0 mm ²), 2x (0.5 ... 1.0 mm ²) 1x (0.5 ... 1.5 mm ²), 2x (0.5 ... 1.5 mm ²) 1x (20 ... 16), 2x (20 ... 16) 1x (20 ... 16), 2x (20 ... 16)
type of electrical connection plug-in socket	No
Approvals Certificates	
General Product Approval	EMV



Functional Safety	Test Certificates	Maritime application
Type Examination Certificate	Type Test Certificates/Test Report	

other	Railway	Environment
	Confirmation	Confirmation
		Environmental Confirmations

Further information

Information on the packaging
<https://support.industry.siemens.com/cs/ww/en/view/109813875>
Information for data generation and storage
<https://support.industry.siemens.com/cs/ww/en/view/109995012>
Information- and Downloadcenter (Catalogs, Brochures,...)
<https://www.siemens.com/ic10>
Industry Mall (Online ordering system)
<https://mall.industry.siemens.com/mall/en/en/Catalog/product?mlfb=3SK1122-2CB41>
Cax online generator
<https://support.automation.siemens.com/WW/CAXorder/default.aspx?lang=en&mlfb=3SK1122-2CB41>
Service&Support (Manuals, Certificates, Characteristics, FAQs,...)
<https://support.industry.siemens.com/cs/ww/en/ps/3SK1122-2CB41>
Image database (product images, 2D dimension drawings, 3D models, device circuit diagrams, EPLAN macros, ...)
https://www.automation.siemens.com/bilddb/cax_de.aspx?mlfb=3SK1122-2CB41&lang=en

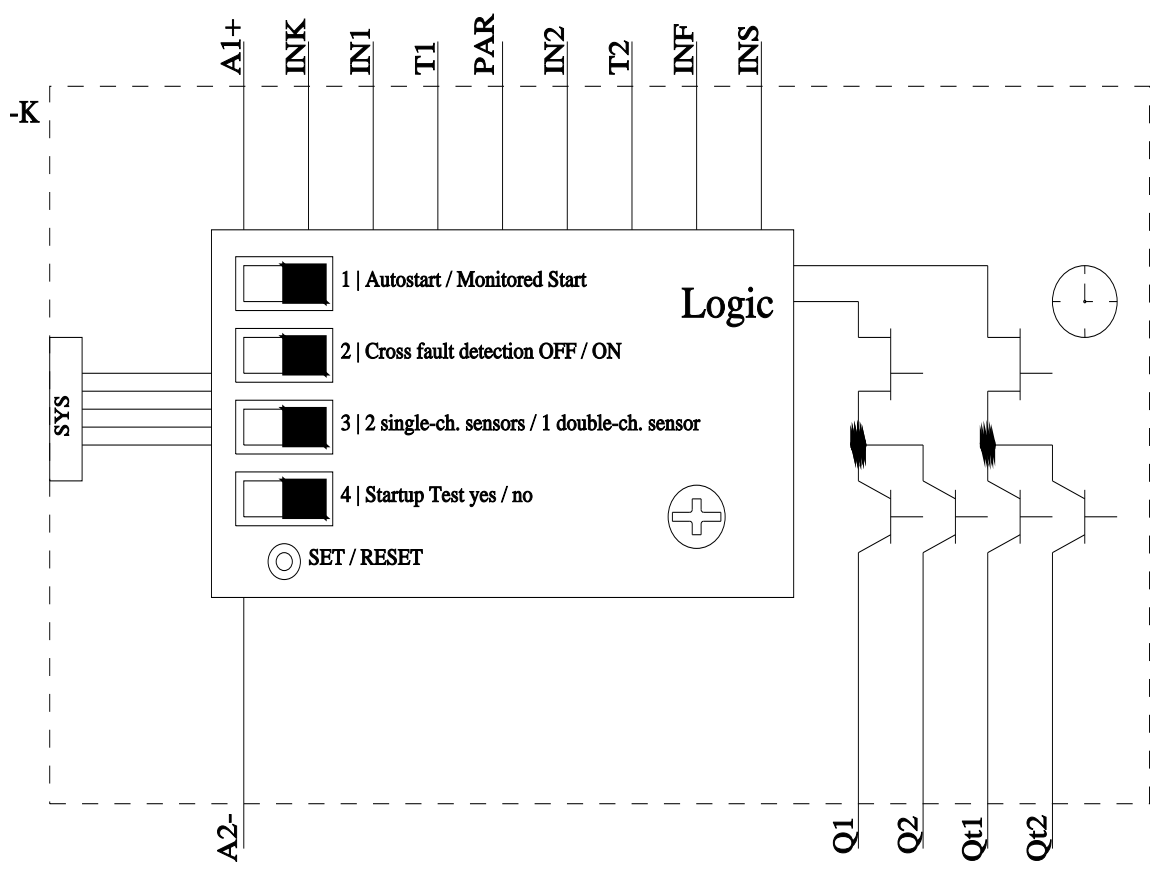
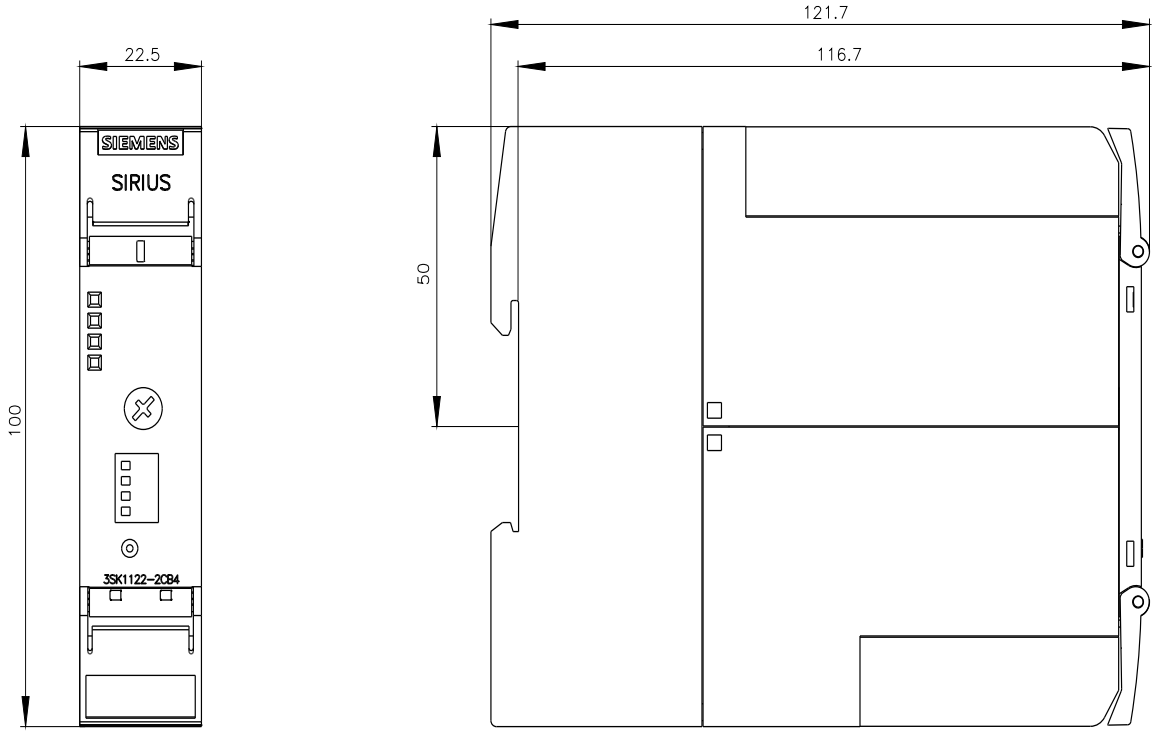

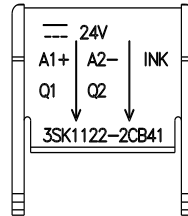
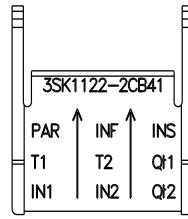
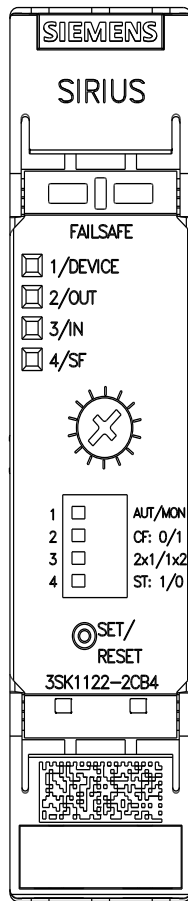

last modified:

10/7/2025