







motorized operating mechanism MO 24...30 V AC/DC accessories for circuit breakers 3WL10 / 3VA27 (SE)

Model		
product brand name	SENTRON	
product designation	motor operator MO	
design of the product	24...30 V AC/DC	
Accessories		
accessories	Accessories for 3WL10 / 3VA27 circuit breakers	
Mechanical Design		
height	61 mm	
width	90 mm	
depth	140 mm	
Net Weight	786 g	
Approvals Certificates		
General Product Approval	Maritime application	other
	 EG-Konf.	Confirmation
		 LRS
		
other	Environment	
Confirmation	Environmental Confirmations	

Further information

- Information on the packaging
<https://support.industry.siemens.com/cs/ww/en/view/109813875>
- Information for data generation and storage
<https://support.industry.siemens.com/cs/ww/en/view/109995012>
- Information- and Downloadcenter (Catalogs, Brochures,...)
<https://www.siemens.com/lowvoltage/catalogs>
- Industry Mall (Online ordering system)
<https://mall.industry.siemens.com/mall/en/en/Catalog/product?mlfb=3VW9011-0AF01>
- Service&Support (Manuals, Certificates, Characteristics, FAQs,...)
<https://support.industry.siemens.com/cs/ww/en/ps/3VW9011-0AF01>
- Image database (product images, 2D dimension drawings, 3D models, device circuit diagrams, ...)
https://www.automation.siemens.com/bilddb/cax_en.aspx?mlfb=3VW9011-0AF01
- CAX-Online-Generator
<https://www.siemens.com/cax>
- Tender specifications

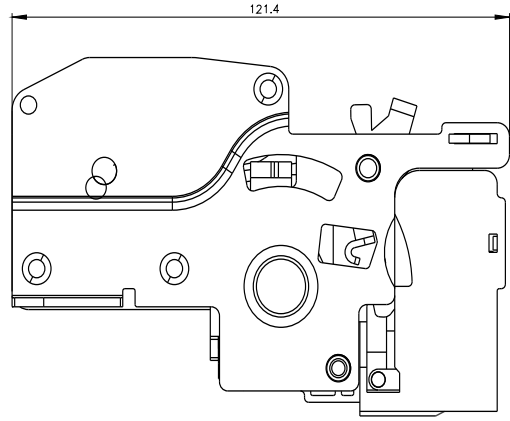
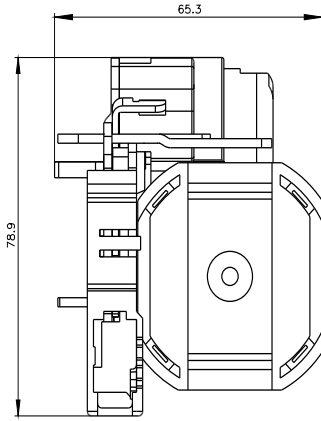

last modified:

4/4/2025 

