



motorized operating mechanism MO 48...60 V AC/DC accessories for circuit breakers 3WL10 / 3VA27 (SE)

Model	
product brand name	SENTRON
product designation	motor operator MO
design of the product	48...60 V AC/DC
Accessories	
accessories	Accessories for 3WL10 / 3VA27 circuit breakers
Mechanical Design	
height	61 mm
width	90 mm
depth	140 mm
Net Weight	0.8 kg

Approvals Certificates		
General Product Approval	Maritime application	other

[Confirmation](#)



other	Environment
-------	-------------

[Confirmation](#)

[Environmental Confirmations](#)

### Further information

- Information on the packaging  
<https://support.industry.siemens.com/cs/ww/en/view/109813875>
- Information for data generation and storage  
<https://support.industry.siemens.com/cs/ww/en/view/109995012>
- Information- and Downloadcenter (Catalogs, Brochures,...)  
<https://www.siemens.com/lowvoltage/catalogs>
- Industry Mall (Online ordering system)  
<https://mall.industry.siemens.com/mall/en/en/Catalog/product?mlfb=3VW9011-0AF02>
- Service&Support (Manuals, Certificates, Characteristics, FAQs,...)  
<https://support.industry.siemens.com/cs/ww/en/ps/3VW9011-0AF02>
- Image database (product images, 2D dimension drawings, 3D models, device circuit diagrams, ...)  
[https://www.automation.siemens.com/bilddb/cax\\_en.aspx?mlfb=3VW9011-0AF02](https://www.automation.siemens.com/bilddb/cax_en.aspx?mlfb=3VW9011-0AF02)
- CAX-Online-Generator  
<https://www.siemens.com/cax>
- Tender specifications

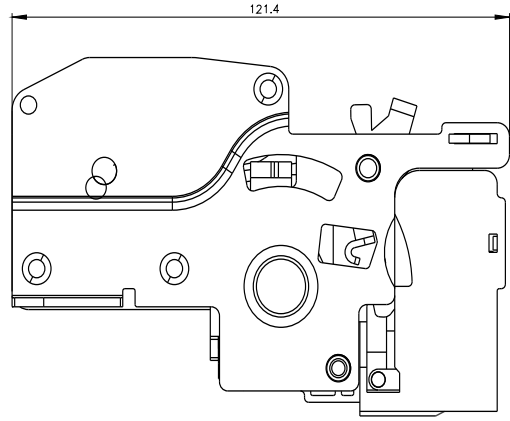
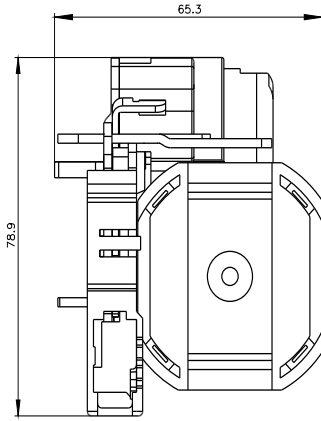

---

last modified:

4/4/2025 

