

Main contact system for circuit breakers fixed mounted and withdrawable, Frame Size 1, 3-pole, for 3WA2 breaking capacity class N, In = 800-1200A, for 3WA3 breaking capacity class N, In = 800-1200A, 3 pieces

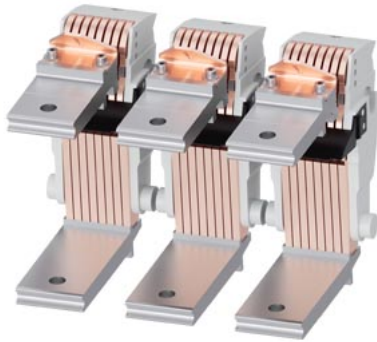

**Model**

product brand name	SENTRON
Net Weight	6.98 kg

**Approvals Certificates**

General Product Approval	EMV	Test Certificates
--------------------------	-----	-------------------



[Confirmation](#)



[Type Test Certificates/Test Report](#)

[Special Test Certificate](#)

Test Certificates	Maritime application	other
-------------------	----------------------	-------

[Miscellaneous](#)



[Confirmation](#)



**Further information**

- Information on the packaging  
<https://support.industry.siemens.com/cs/ww/en/view/109813875>
- Information for data generation and storage  
<https://support.industry.siemens.com/cs/ww/en/view/109995012>
- Information- and Downloadcenter (Catalogs, Brochures,...)  
<https://www.siemens.com/lowvoltage/catalogs>
- Industry Mall (Online ordering system)  
<https://mall.industry.siemens.com/mall/en/en/Catalog/product?mlfb=3WA9111-1AQ30>
- Service&Support (Manuals, Certificates, Characteristics, FAQs,...)  
<https://support.industry.siemens.com/cs/ww/en/ps/3WA9111-1AQ30>
- Image database (product images, 2D dimension drawings, 3D models, device circuit diagrams, ...)  
[https://www.automation.siemens.com/bilddb/cax\\_en.aspx?mlfb=3WA9111-1AQ30](https://www.automation.siemens.com/bilddb/cax_en.aspx?mlfb=3WA9111-1AQ30)
- CAX-Online-Generator  
<https://www.siemens.com/cax>
- Tender specifications  
<https://www.siemens.com/specifications>

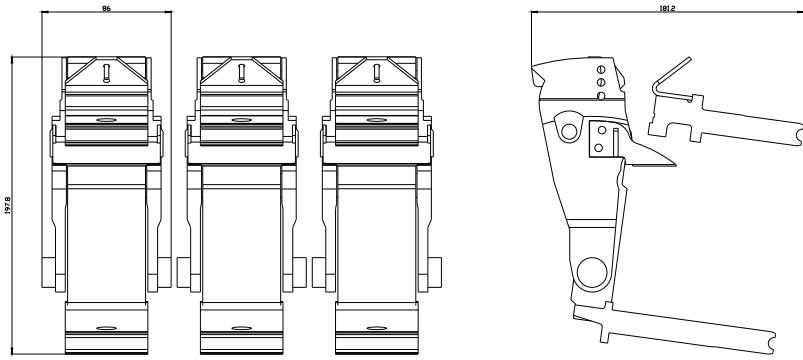

---

last modified:

10/18/2025 

